

Items Supplied >

- 1 – Powrpro Black Fuel Injection Module
- 1 – 6" 18# Test Zip Tie
- 1 – Velcro strip

Application(s) >

Kawasaki Vulcan 900 06-16

Instruction Manual >

92-1968B

Page 1 of 2

Read all instructions carefully and completely before installing your new POWRPRO module. It is recommended that a qualified mechanic or technician install this product. Before installing it is recommended that the gas tank be low on fuel.

1. Remove the seat. Remove the outer chrome air cleaner cover, and then remove the air filter element by removing the Phillips screw at the top of the filter. Now remove the five Allen head bolts around the air intake boot and remove the two lower allen bolts holding the back housing on, see Figure 1. Pull the housing far enough forward to access and unplug the large breather hose, the intake air sensor wire plug, and the idle control cable. Now lower the housing out of the way.
2. Remove the two bolts at the rear of the gas tank and lift the tank about three inches and securely prop it in that position. Remove the two screws that retain the battery cover / tool kit tray and remove it.
3. Route the Fi2000 harness forward from the battery area, under the frame through the opening where the stock harness is routed. Feed the harness forward on the left side of the engine, and then route it back under the frame (just ahead of the rear cylinder head) to the throttle bodies.
4. Locate and unplug the stock fuel injectors on the top of the throttle body. Plug the matching Fi2000 connectors onto the injectors; the longer female Fi2000 connector plugs onto the forward injector see Figure 2. Now plug the original female connectors into the corresponding black male Fi2000 connectors. Ziptie the Fi2000 harness to the main harness, see Figure 2.
5. Attach the black ground wire to the negative post of the battery and Velcro the Fi2000 module to the battery cover / tool kit tray as shown in Figure 3. Prior to reinstalling the seat, verify connections and proper LED Functions.
6. Verify that the module has power and connections have been made correctly; watch the clear window on the FI housing and turn "ON" the key ignition and set the handlebar run switch to "ON", confirm that the Red LED turns on. On some models the Red light will turn off after 4-5 seconds as the fuel pump cycles off, which is OK. If you do not see a Red light, it may be necessary to wait for the alarm to reset (if applicable) and try again. Also confirm the side stand is up, bike is in neutral, and clutch is in. Start the bike and confirm the LED remains on solid Red. **NOTE:** Make sure ignition is turned off before attempting to change any Fi2000 harness connections if no Red light is seen. For access to the Blue Tooth Tuning App on the module, please download the PowrPro Black App to your smart device, Android 4.3 & later or Apple iOS 5.0 & later operating systems. Once the app is installed, make sure the motorcycle is in neutral and start the engine, use the connect button within the app and the Blue light on the Fi module window will light up during pairing connection and remain solid Blue while paired and connected with respective Android or Apple Device. Once the app has been used and settings saved and disconnected through the app, the Blue light will turn off, and the PowrPro Black will be ready for continued service on the motorcycle.

DISCLAIMER: NOT LEGAL FOR SALE OR USE IN CALIFORNIA ON ANY POLLUTION CONTROLLED MOTOR VEHICLES.

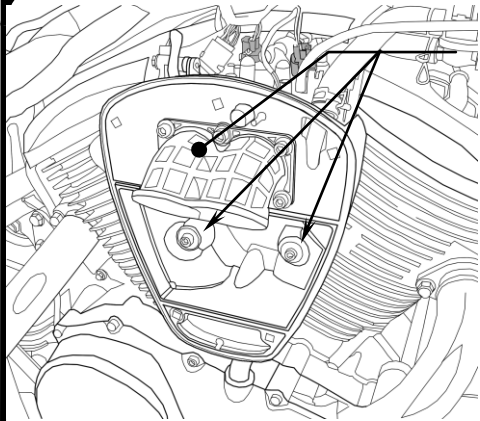

REMOVE 5 BOLTS FROM AIR INTAKE BOOT AND 2 FROM HOUSING

ZIP TIE TO STOCK HARNESS

MALE Fi2000 CONNECTOR ATTACHED TO FACTORY FEMALE CONNECTOR

FEMALE Fi2000 CONNECTOR ATTACHED TO FUEL INJECTOR

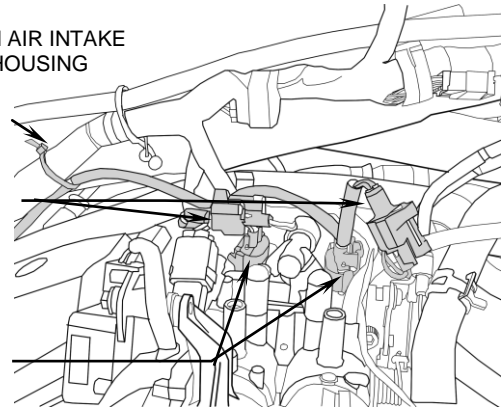
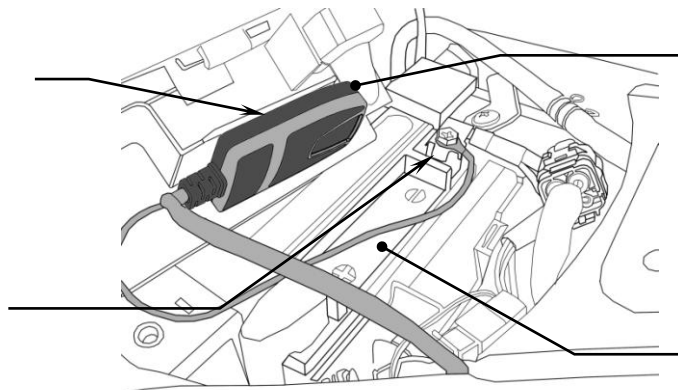

FIGURE 1: LEFT SIDE INJECTOR

FIGURE 2: RIGHT SIDE INJECTOR

Fi2000 BOX INSTALLATION LOCATION

GROUND WIRE CONNECTION LOCATION



BATTERY COVER / TOOL KIT TRAY (UNBOLTED)

BATTERY

FIGURE 3: Fi2000 ECU INSTALLATION LOCATION

DISCLAIMER: NOT LEGAL FOR SALE OR USE IN CALIFORNIA ON ANY POLLUTION CONTROLLED MOTOR VEHICLES.