

## Items Supplied >

- 1 – Fi2000R Fuel Injection Module
- 1 – Zip Tie, (1): 3/16" x 8"
- 1 – Velcro Strip

## Application(s) >

YAMAHA RAIDER 2008-2013

## Instruction Manual >

92-1777CL

Page 1 of 3

**Read all instructions carefully and completely before installing your new Fi2000CL module. It is recommended that a qualified mechanic or technician install this product. Before installing the Fi2000CL it is recommended that the fuel tank be low on fuel.**

1. Remove the seat, and the chrome right hand cover from the engine. Remove the two dome head nuts holding the rear of the fuel tank on.
2. Position the Fi2000 on top of the ECU (under the seat) and feed the wire harness under the front seat bracket, then feed the harness forward underneath the rear fuel tank mounting bracket. Lift up the fuel tank just enough to slip the wire harness under the rear of the fuel tank, make sure the harness does not get pinched between the fuel tank and the frame as the tank is lowered down, see Figure 1. Zip-tie the harness to the other harnesses under the tank.
3. Feed the remaining portion of the wire harness forward and down through the coil bracket opening, see Figure 2. Locate the white Raider 6-pin connector behind the coil-mounting bracket; disconnect this connector.
4. Plug the Fi2000 connectors into the corresponding 6 pin connectors that were previously unplugged in Step 3. Reinstall the chrome right side cover.
5. Locate the oxygen sensor on the muffler body near the power valve and trace the wire on it back up to under the seat, where it's male and female connectors are located. Move the fuse block out of the way, by depressing the plastic tab between the housing and the steel-mounting tab, and pull it upward out of the way to gain access to the oxygen sensor connectors mounted on the plastic tab. Disconnect the oxygen sensor by pulling the tab on the female connector outward and pulling the male connector towards the front of the bike, see Figure 3.
6. Feed the female oxygen sensor connector and harness from the Fi2000 down to the stock male oxygen sensor connector, and connect the two. Now connect the male Fi2000 oxygen sensor connector to the stock female oxygen sensor connector, see Figure 4, once this has been done reinstall the fuse block onto its mounting tab.
7. Using the supplied Velcro pads, place the module in the position shown, in Figure 5. Attach the black ground wire from the Fi2000 to the 5 mm socket head bolt securing the battery ground wire, see Figure 5. Before reinstalling the seat, verify connections.
8. Remove the door from the Fi2000 module to expose the LED's. **NOTE:** The Fi2000 base pot settings come preset from the factory for the Raider, shown in Figure 6. Verify the wire connections by, (1), turning the ignition on while watching the 3 LED's. They will all light up for a few seconds, and then go off. This is correct. If there are no lights visible, make sure the side stand is up, bike is in neutral, clutch is in and handlebar engine switch is set to run. If there are still no lights visible, re-check that all connectors are fully engaged and the ground wire is connected correctly. (2), after achieving a steady light from all three LED's, start the motorcycle; the green light should now be the only LED on. If all three LED's are still on after start up, verify the injector connectors are correctly attached. Reattach the access door when finished and install the remaining components. **NOTE:** Make sure the ignition is turned off before changing any connections.

**\* It is recommended that you always wear a helmet while riding. Please never operate your motorcycle while under the influence of alcohol and/or drugs. Enjoy the new power of your motorcycle and please ride safely.**

## ADVANCED TUNING

Your Cobra® Fi2000 fuel injection module has been tested and preset for best function and rideability on a motorcycle with aftermarket aircleaner and Cobra exhaust. The Fi2000 does however, have 3 important adjustments that allow you to tune the module for optimum performance, especially if you have performed other changes to your motorcycle. These adjustments also allow you to resolve drivability issues if our stock settings are not exactly right for your bike. Make sure your motorcycle is up to normal operating temperature (15 minutes of riding should be sufficient) before making any adjustments. Remove the door to expose the pots shown in Figure 4.

**GREEN LED POT (left pot)** – With the Closed Loop function of this module you do not need to adjust this setting, leave it at 1.0. Without a closed loop system this adjustment would affect idle and cruise fuel. If you had cruising issues, this is where you would try a different setting. Generally, surging and uneven running while cruising is a lean fuel condition, so adding a small increase in fuel by turning this adjustment clockwise with a small flat blade screwdriver a 1/2 of a position would help. The bike would need to be Test-driven to feel an improvement and only the setting would need to be increased until the surge went away. Also, backfiring or popping on trailing throttle is generally a lean symptom (or an exhaust gasket leak). The same small increases as above would be tried just until the backfiring would disappear.

**YELLOW LED POT (middle pot)** - this adjustment affects acceleration and power fuel. If you have a hesitation or bogging on acceleration, this is where you would try a different setting. Aftermarket air cleaner assemblies generally lean out fuel mixtures, so try small clockwise increases as above until a smooth acceleration returns.

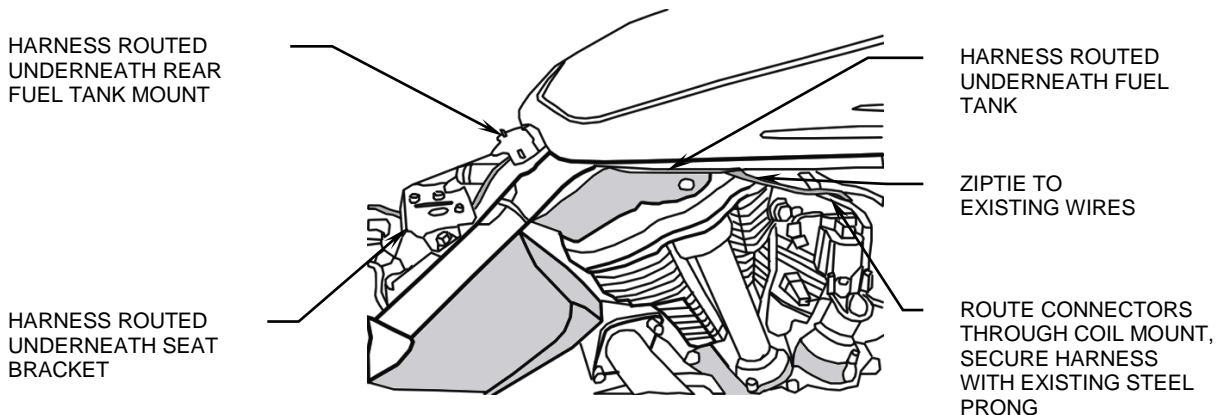
**RED LED POT (right pot)** - this adjustment is the top end or power fuel adjustment. Just like the main jet in a carburetor, it starts to control fuel, as you demand maximum power from your bike and takes over completely above 4000 R.P.M. As performance gains are added to your motorcycle, such as big bore kits, camshafts, flowed cylinder heads, etc., each component will increase the fuel demand of the system. With the red pot turned to its maximum (10) position, the Fi2000 will cope with nearly 100 R.W. horsepower. An all-stock motor will only require a 2 position. You can generally, if you are using quality performance engine upgrades, in a sensible combination equate the numbers evenly from 2 up to 10 based on horsepower gains.

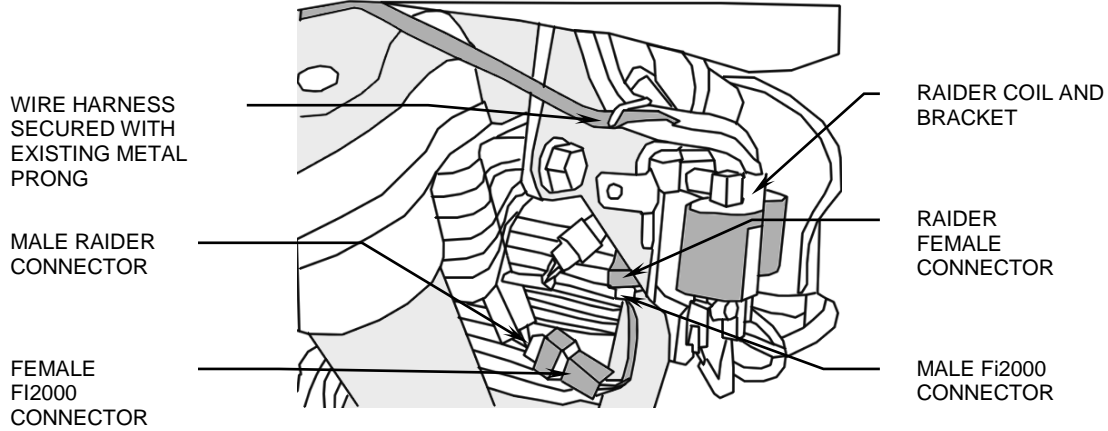
## TUNING NOTES

Typically 2 into 1 or our speedster exhaust system require one additional position, on the yellow and red pots, over slip-ons or staggered duals. On high performance motors, slip-on mufflers do not flow well enough and create fuel setting problems and detonation. Cobra recommends the installation of any of its complete exhaust systems.

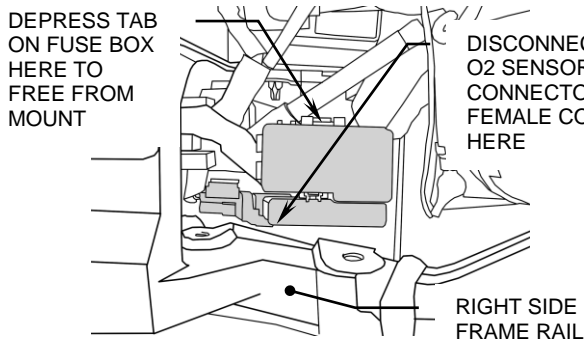
## TROUBLE SHOOTING

If you have any problems refer to: Step 8, in the installation body of these instructions.



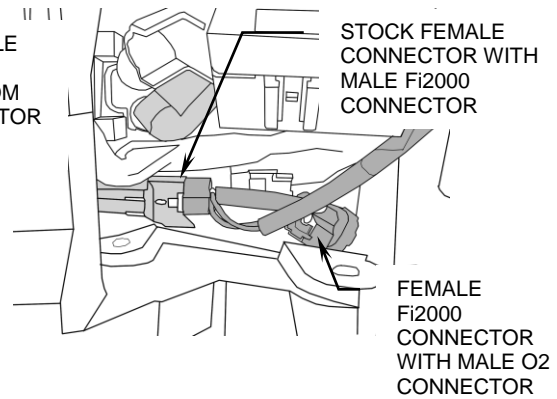


**FIGURE 2**

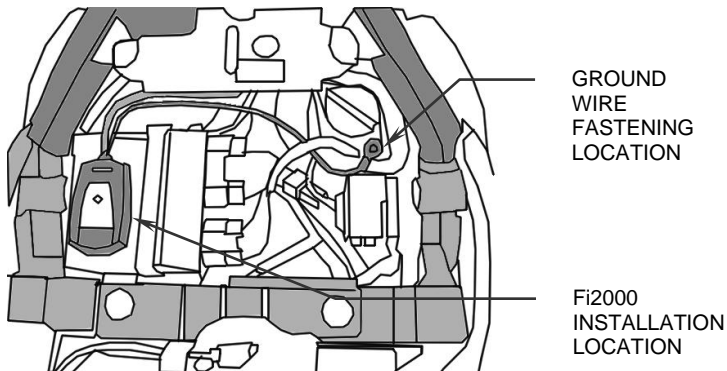


**FIGURE 3**

DISCONNECT MALE O2 SENSOR CONNECTOR FROM FEMALE CONNECTOR HERE

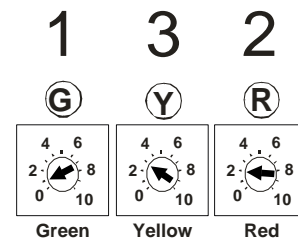


**FIGURE 4**



**FIGURE 5**

**Default Pot Settings:**



**FIGURE 6**