

## Items Supplied >

- 1 – Powrpro Black Fuel Injection Module
- 1 – Zip Tie, 3/16" x 8"
- 1 – Velcro Strip

## Application(s) >

YAMAHA RAIDER 2008-2016

## Instruction Manual >

92-1777B

Page 1 of 3

**Read all instructions carefully and completely before installing your new POWRPRO module. It is recommended that a qualified mechanic or technician install this product. Before installing it is recommended that the fuel tank be low on fuel.**

1. Remove the seat, and the chrome right hand cover from the engine. Remove the two dome head nuts holding the rear of the fuel tank on.
2. Position the Fi2000 on top of the ECU (under the seat) and feed the wire harness under the front seat bracket, then feed the harness forward underneath the rear fuel tank mounting bracket. Lift up the fuel tank just enough to slip the wire harness under the rear of the fuel tank, make sure the harness does not get pinched between the fuel tank and the frame as the tank is lowered down, see Figure 1. Zip-tie the harness to the other harnesses under the tank.
3. Feed the remaining portion of the wire harness forward and down through the coil bracket opening, see Figure 2. Locate the white Raider 6-pin connector behind the coil-mounting bracket; disconnect this connector.
4. Plug the Fi2000 connectors into the corresponding 6 pin connectors that were previously unplugged in Step 3. Reinstall the chrome right side cover.
5. Locate the oxygen sensor on the muffler body near the power valve and trace the wire on it back up to under the seat, where it's male and female connectors are located. Move the fuse block out of the way, by depressing the plastic tab between the housing and the steel-mounting tab, and pull it upward out of the way to gain access to the oxygen sensor connectors mounted on the plastic tab. Disconnect the oxygen sensor by pulling the tab on the female connector outward and pulling the male connector towards the front of the bike, see Figure 3.
6. Feed the female oxygen sensor connector and harness from the Fi2000 down to the stock male oxygen sensor connector, and connect the two. Now connect the male Fi2000 oxygen sensor connector to the stock female oxygen sensor connector, see Figure 4, once this has been done reinstall the fuse block onto its mounting tab.
7. Using the supplied Velcro pads, place the module in the position shown, in Figure 5. Attach the black ground wire from the Fi2000 to the 5 mm socket head bolt securing the battery ground wire, see Figure 5. Before reinstalling the seat, verify connections.

**DISCLAIMER: NOT LEGAL FOR SALE OR USE IN CALIFORNIA ON ANY POLLUTION CONTROLLED MOTOR VEHICLES.**

8. Verify that the module has power and connections have been made correctly; watch the clear window on the FI housing and turn "ON" the key ignition and set the handlebar run switch to "ON", confirm that the Red LED turns on. On some models the Red light will turn off after 4-5 seconds as the fuel pump cycles off, which is OK. If you do not see a Red light, it may be necessary to wait for the alarm to reset (if applicable) and try again. Also confirm the side stand is up, bike is in neutral, and clutch is in. Start the bike and confirm the LED remains on solid Red. **NOTE:** Make sure ignition is turned off before attempting to change any Fi2000 harness connections if no Red light is seen. For access to the Blue Tooth Tuning App on the module, please download the PowrPro Black App to your smart device, Android 4.3 & later or Apple iOS 5.0 & later operating systems. Once the app is installed, make sure the motorcycle is in neutral and start the engine, use the connect button within the app and the Blue light on the Fi module window will light up during pairing connection and remain solid Blue while paired and connected with respective Android or Apple Device. Once the app has been used and settings saved and disconnected through the app, the Blue light will turn off, and the PowrPro Black will be ready for continued service on the motorcycle.

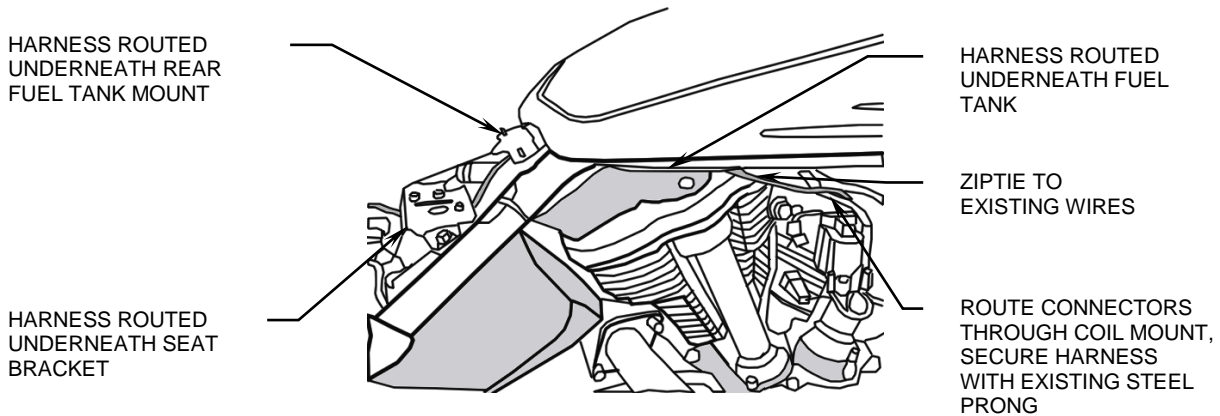

FIGURE 1

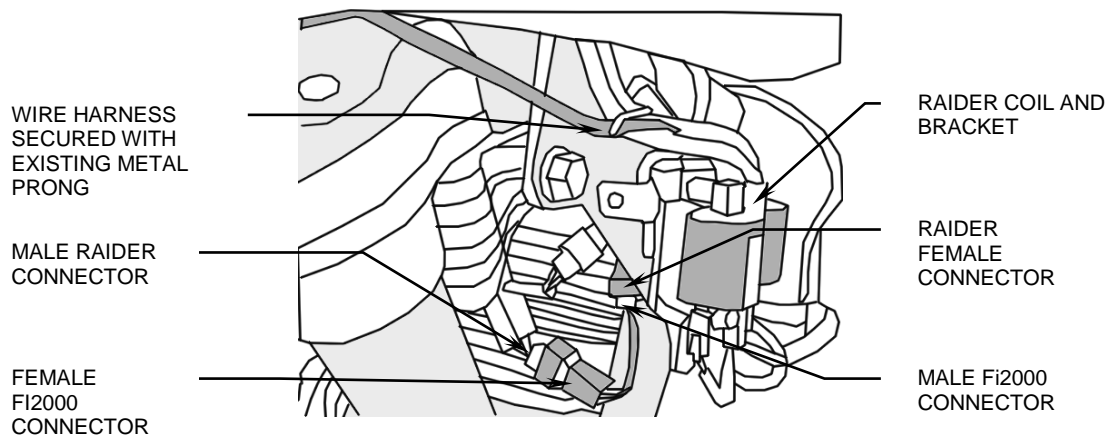
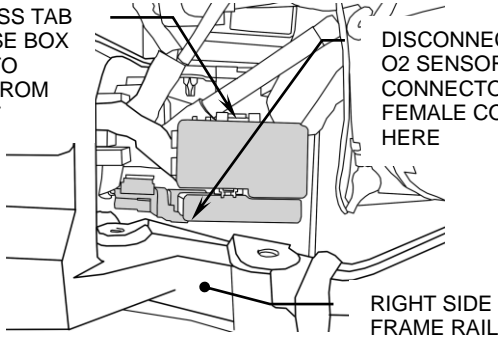

FIGURE 2

DEPRESS TAB ON FUSE BOX HERE TO FREE FROM MOUNT



DISCONNECT MALE O2 SENSOR CONNECTOR FROM FEMALE CONNECTOR HERE

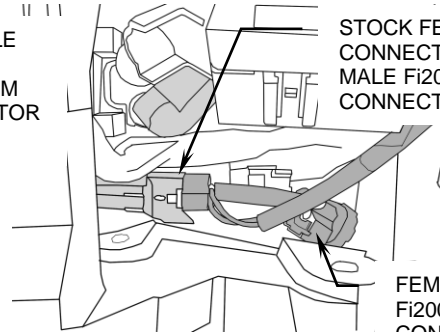

FIGURE 3

FIGURE 4

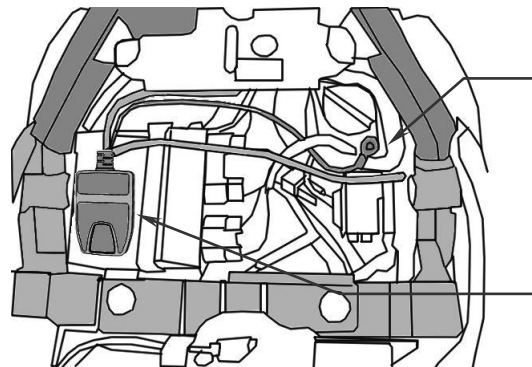

FIGURE 5

**DISCLAIMER:** NOT LEGAL FOR SALE OR USE IN CALIFORNIA ON ANY POLLUTION CONTROLLED MOTOR VEHICLES.