

Items Supplied >

- 1 – Powrpro Black Fuel Injection Module
- 1 – Zip Tie, (1): 3/16" x 8"
- 1 – Velcro Strip

Application(s) >

- | | |
|--------------------|-----------|
| YAMAHA ROADLINER | 2006-2014 |
| YAMAHA STRATOLINER | 2006-2014 |

Instruction Manual >

92-1773B

Page 1 of 3

Read all instructions carefully and completely before installing your new POWRPRO module. It is recommended that a qualified mechanic or technician install this product. Before installing it is recommended that the fuel tank be low on fuel.

1. Remove the seat, and the chrome right hand cover from the engine. Remove the two dome head nuts holding the rear of the fuel tank on. If the motorcycle is being worked on in a motorcycle stand, it will be necessary to gain extra clearance when lifting the rear of the fuel tank for installation of the Fi2000 wire harness. To do this, remove the decorative trim from the front of the fuel tank, to prevent from damaging it. It may also be necessary to remove the button head socket screws securing the instrument bezel / gauge cluster, so it maybe removed for clearance at the front of the fuel tank.
2. Position the Fi2000 on top of the ECU (under the seat) and feed the fuel injector wire harness under the front seat bracket, then feed the harness forward underneath the rear fuel tank mounting bracket. Lift up the fuel tank just enough to slip the wire harness under the rear of the fuel tank, make sure the harness does not get pinched between the fuel tank and the frame as the tank is lowered down, see Figure 1. Zip-tie the harness to the other harnesses under the tank.
3. Feed the remaining portion of the wire harness forward and down through the coil bracket opening, see Figure 2. Locate the white Roadliner 6-pin connector behind the coil-mounting bracket; disconnect this connector.
4. Plug the Fi2000 connectors into the corresponding 6 pin connectors that were previously unplugged in Step 3. Reinstall the chrome right side cover.
5. Remove the socket head screw securing the O₂ sensor harness and bracket to engine case on the right side of the motorcycle, see Figure 3, unplug the stock male and female connectors, and route the Fi2000 O₂ connectors to this location and insert into corresponding connectors. The routing of the harness will need to be from the under seat area, to behind the oil tank and down to this area where the connectors are. It may be necessary to pull the harnesses outward to assemble once routed down behind the oil tank, then reposition behind the frame rail and reattach the mounting bracket to the case and tighten to proper factory torque specification.
6. Using the supplied Velcro pads, place the module in the position shown, in Figure 4. Attach the black ground wire from the Fi2000 to the 5mm allen head bolt securing the battery ground wire, see Figure 4. Before reinstalling the seat, verify connections.

DISCLAIMER: NOT LEGAL FOR SALE OR USE IN CALIFORNIA ON ANY POLLUTION CONTROLLED MOTOR VEHICLES.

7. Verify that the module has power and connections have been made correctly; watch the clear window on the FI housing and turn "ON" the key ignition and set the handlebar run switch to "ON", confirm that the Red LED turns on. On some models the Red light will turn off after 4-5 seconds as the fuel pump cycles off, which is OK. If you do not see a Red light, it may be necessary to wait for the alarm to reset (if applicable) and try again. Also confirm the side stand is up, bike is in neutral, and clutch is in. Start the bike and confirm the LED remains on solid Red. **NOTE:** Make sure ignition is turned off before attempting to change any Fi2000 harness connections if no Red light is seen. For access to the Blue Tooth Tuning App on the module, please download the PowrPro Black App to your smart device, Android 4.3 & later or Apple iOS 5.0 & later operating systems. Once the app is installed, make sure the motorcycle is in neutral and start the engine, use the connect button within the app and the Blue light on the Fi module window will light up during pairing connection and remain solid Blue while paired and connected with respective Android or Apple Device. Once the app has been used and settings saved and disconnected through the app, the Blue light will turn off, and the PowrPro Black will be ready for continued service on the motorcycle.

HARNESS Routed UNDERNEATH REAR FUEL TANK MOUNT

HARNESS Routed UNDERNEATH SEAT BRACKET

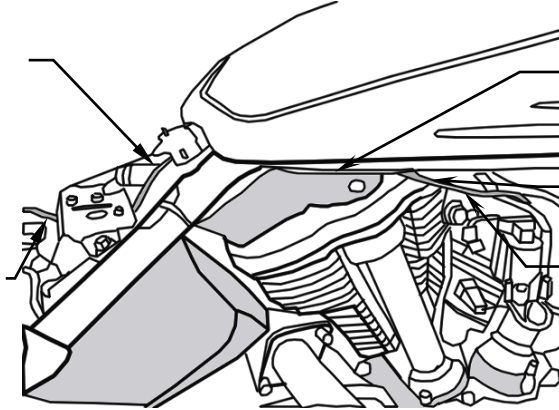

HARNESS Routed UNDERNEATH FUEL TANK

ZIPTIE TO EXISTING WIRES

ROUTE CONNECTORS THROUGH COIL MOUNT, SECURE HARNESS WITH EXISTING STEEL PRONG

FIGURE 1

WIRE HARNESS SECURED WITH EXISTING METAL PRONG

Fi2000 / ROADLINER 6 PIN FUEL INJECTOR CONNECTORS

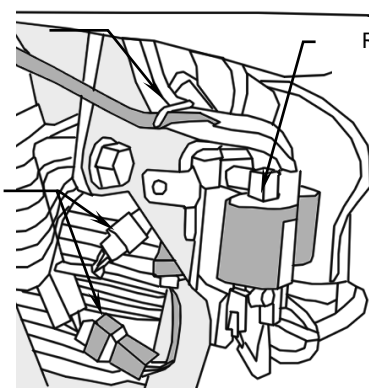

ROADLINER COIL AND BRACKET

CASE BOLT & BRACKET SECURING O₂ SENSOR

WIRE HOOK SECURING O₂ SENSOR HARNESS

RIGHT SIDE ENGINE CASE

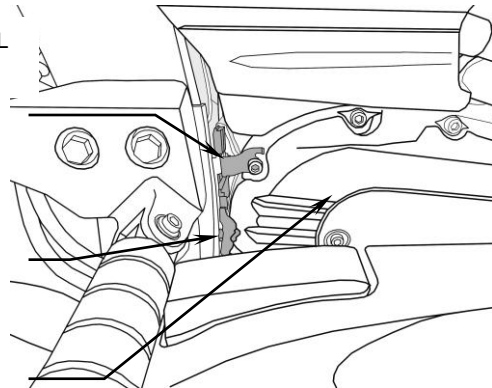
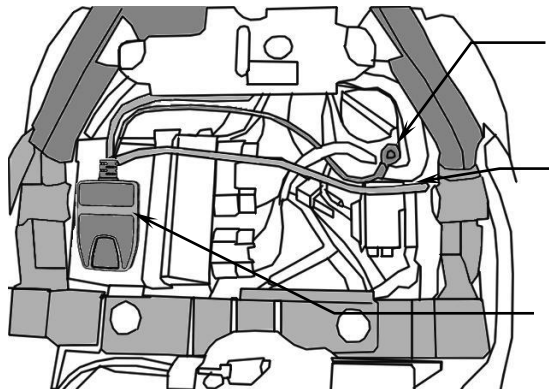

FIGURE 2

FIGURE 3



GROUND WIRE FASTENING LOCATION

O₂ SENSOR HARNESS ROUTING

Fi2000 INSTALLATION LOCATION

FIGURE 4

DISCLAIMER: NOT LEGAL FOR SALE OR USE IN CALIFORNIA ON ANY POLLUTION CONTROLLED MOTOR VEHICLES.