

## Items Supplied >

- 1 – Fi2000 FUEL INJECTION MODULE
- 2 – 4" ZIP TIES NARROW #18 TEST
- 1 – VELCRO STRIP

## Application(s) >

HONDA FURY	2010-2019
SABRE	2010-2014
STATELINE	2010-2016
INTERSTATE	2010-2015

## Instruction Manual >

92-1633

Page 1 of 3

**Read all instructions carefully and completely before installing your new Fi2000 module. It is recommended that a qualified mechanic or technician install this product. Before installing the Fi2000 it is recommended that the gas tank be low on fuel.**

1. Remove the (4) M6 bolts that hold on the right side air cleaner cover then remove the cover and filter. Remove the air cleaner backing plate by loosening the (4) screws around air inlet (Note: screws will not come out they only loosen) and the (1) M6 hex bolt from the backing plate. See Figure 1.
2. Remove the left side battery box cover and left rear cylinder cover. (Note: no screws hold the covers; simply pull loose from rubber grommets).
3. Route the Fi2000 wire harness from the battery location, following along existing harness under the gas tank, to the right side of motorcycle until reaching the fuel injectors and connectors. See Figures 2 & 3.
4. Note which stock injector connectors belong to front and rear injectors. Disconnect the stock injector connector from the front cylinder and connect the longer female Fi2000 connector to that injector – connect corresponding male connector to stock female connector (removed from front cylinder). See Figure 2.
5. Disconnect the stock injector connector from the rear cylinder and connect the shorter female Fi2000 connector to that injector – connect corresponding male connector to stock female connector (removed from rear cylinder). See Figure 2.
6. Reinstall air cleaner backing plate, air filter, and air cleaner cover in the same manner as it was removed.
7. Attach the ground cable to the NEGATIVE post of the battery. See Figure 3.
8. Temporarily place Fi2000 box in a secure location and verify your connections. Remove the door from the Fi2000 box to expose the LED lights and pot setting. Verify the wire connections by (1) turning on the ignition while watching the 3 LEDs, confirm that all 3 LEDs light up and remain on. If you don't see lights, make sure the sidestand is up, bike is in neutral, clutch is in and handle bar engine switch is set to run. If you still have no lights, re-check that all connectors are fully engaged and the ground wire is connected correctly. (2) After achieving a steady light from all three LED's, start the motorcycle; the green light should now be the only LED on. If all three LED's are still on after start up, verify you have attached the injector connectors correctly. Reattach the access door when finished. **Note:** Make sure the ignition is turn off before changing any connection.
9. Using the supplied Velcro, mount the Fi2000 module as shown in Figure 4. Zip tie the Fi2000 harness to stock tubes/wire harnesses in the locations shown in Figure 3.
10. Reinstall the battery box cover and rear cylinder cover.

**\*For California riders we offer Air Resources Board approved Fi2000 ARB units with Executive Order number D-633-2. All other Fi2000 models are not legal for street use in California. Visit COBRAUSA.COM to choose the correct Fi2000 for your vehicle.**

**ADVANCED TUNING**

The Fi2000 has the ability to efficiently tune the EFI system on your motorcycle for slip-on or full exhaust systems. It comes pre-set from the factory for popular brand name full exhaust systems. Both dyno testing and on-road exhaust gas analysis have been used to develop the best base settings for drivability and power.

Not all slip-on mufflers flow exactly the same. Some eliminate power valves and others don't. Some are made with street baffles, other with race or competition baffles. Full exhaust systems offer even greater variation in construction, features and performance. The Fi2000 has the ability to tune the EFI system on your motorcycle to any of these exhausts by applying a logical and systematic approach to altering the base settings supplied with your Fi2000. These suggestions should be followed step by step and help you achieve success.

**\*\* Only attempt adjustments on a fully warmed motor \*\***

1. Start with the base setting in Figure 5 if a full exhaust system is installed. Refer to Step 2 if the stock exhaust is installed or a slip-on muffler is being used to determine the proper pot settings. Adjust and test only ONE adjustment pot at a time until you are happy with the result.
2. Start with the left hand or green light pot. This adjustment works either from idle or above idle (varies with bike) to a R.P.M. of about 5000 (also varies with bike) while the bike is driven at a steady throttle or slowly increasing throttle. This is the cruise range and is where the emissions leanness creates issues like choppy on-off throttle application, surging, and backfiring on trailing throttle.
3. Turn this pot back to zero, and make one position increases until you feel the best performance in this range. Do this test a few times to make sure you have it right.
4. The middle or yellow pot is an engine load- triggered fuel adding adjustment. A rapid increase of the throttle at any R.P.M. will add additional fuel and as long as that predetermined load is present, fuel will continue. As engine loads increase in higher gears the acceleration fuel will stay on longer and be more effective. Starting with the base setting, test ride the motorcycle in 4<sup>th</sup> or 5<sup>th</sup> gear and perform moderately fast roll-on throttle from a repeating standard R.P.M. or speed. Increase the pot one position at a time and stop as soon as you don't feel any improvement.
5. The right hand or red pot is for the fuel setting required when the engine is maximizing its R.P.M. and power delivery. This pot is similar to the main jet in a carburetor. It will take a combination of a minimum R.P.M. and a predetermined amount of engine load to initiate this fuel. The straightaway on a racetrack or an inertia dyno are the best places to set this pot. Full exhaust systems of high quality construction increase flow characteristics and may increase fuel demands over our base settings. Also, air filters specifically designed for higher than stock airflow can create need for higher fuel setting. Try an additional one-position pot setting at a time.
6. Camshaft changes or major air box modifications can alter an engine's volumetric efficiency and create a greater demand on the engine's fuel system than the Fi2000 may have the ability to adjust for.

**TROUBLE SHOOTING**

If you have any problems refer to note 8 in the main body of these instructions.

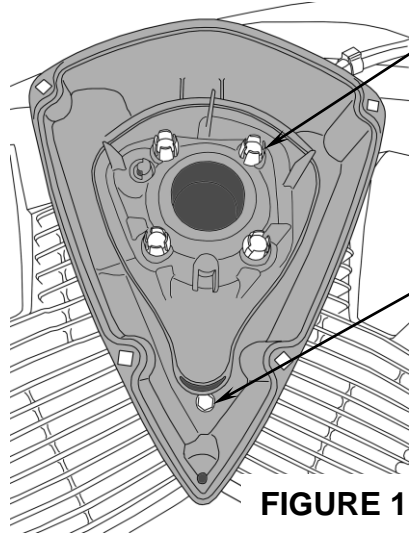
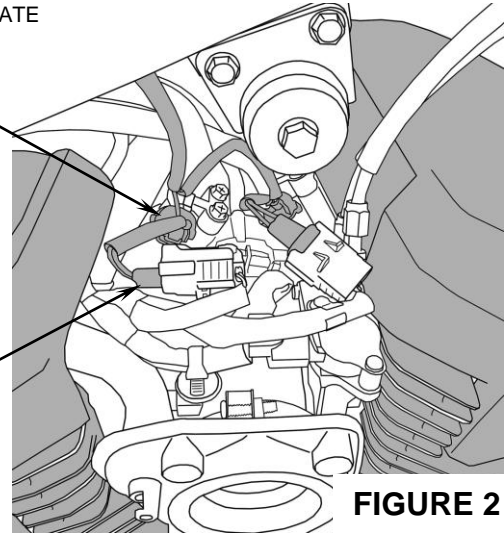

**FIGURE 1**

AIR CLEANER BACKING PLATE  
SCREW 4 PLACES

Fi2000 INJECTOR  
CONNECTOR  
INSTALLED ON STOCK  
FUEL INJECTOR

Fi2000 INJECTOR  
CONNECTOR  
INSTALLED ON STOCK  
CONNECTOR

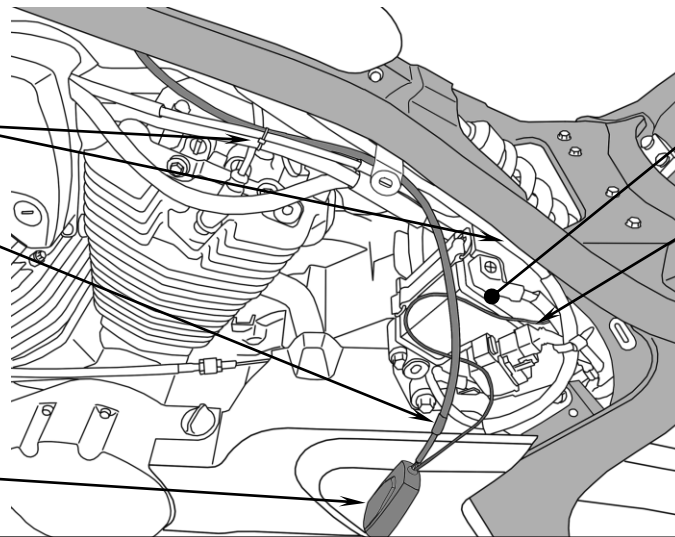

**FIGURE 2**

ZIPTIE Fi2000  
HARNESS TO  
STOCK  
TUBING/WIRES  
(2 LOCATIONS)

Fi2000 HARNESS

Fi2000 BOX  
TEMPORARILY  
HANGING DURING  
INSTALLATION



BATTERY

GROUND WIRE  
ATTACHED TO  
NEGATIVE  
BATTERY POST  
(HIDDEN)

**FIGURE 3**

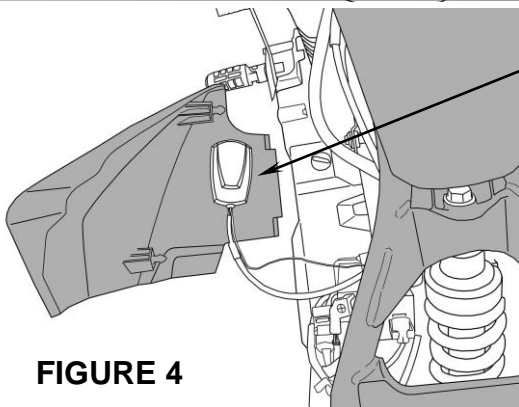

**FIGURE 4**

VELCRO Fi2000 TO  
THE LOCATION  
SHOWN AND  
REINSTALL COVER

**Default Pot Settings**

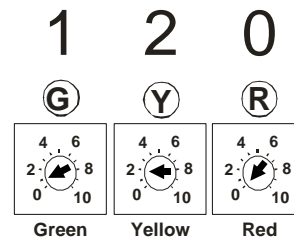

**FIGURE 5**