

Thank you for purchasing this Cobra Dynojet kit. This kit has been developed for a motorcycle which is set to the parameters listed at the right in the "Stage" description. If your motorcycle does not meet any of these parameters please check with Dynojet before installation. For technical assistance contact your Dynojet distributor or call Dynojet U.S.A. (800)-992-4993

Cobra Engineering
 23801 E. La Palma Ave.
 Yorba Linda, CA. 92887
 TEL: 714-692-8180
 FAX: 714-692-5016

Website Address
<http://www.dynojet.com>

The manufacturer and seller make no warranties express or implied which extend beyond the description of the goods contained herein. Any description of this product is for the purpose of identifying it and shall not be deemed to create an express warranty.



92-1272

U.S Models Only

1998-2002 Honda VT1100 Aero

Stage 1

For mildly tuned machines using the stock airbox, with stock filter and Cobra Boulevard exhaust system

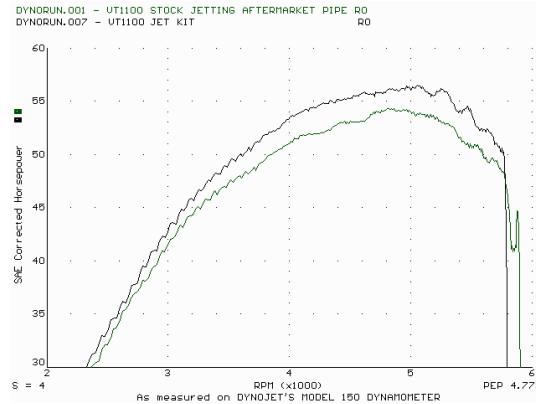

This graph shows a typical gain with a Cobra jet kit.

WARNING

**NO SMOKING!
 NO OPEN FLAME!
 WHILE INSTALLING
 YOUR DYNOJET KIT**

Parts List

1	Main Jet	DJ170
1	Main Jet	DJ175
1	Main Jet	DJ180
2	Fuel Needle	DNO131
2	E-Clip	DE0001
2	Adjusting Washer	DW0001
1	Plug Drill	DD #5/32
1	Screw	DS0001

*For racing use only. Not for sale in the State of California.

STAGE ONE INSTRUCTIONS

COBRA

92-1272

1. Remove vacuum slides from carb. Remove stock needles and spacers, noting order of assembly (Fig. A).

2. Install the Cobra needles on groove #3 from the top. Use all stock spacers (Fig. A). Install the small Cobra washers above the E-clip. **NOTE:** It may be necessary to cut off the top two grooves of the needles to reinstall the stock needle retainer. After installing the slides in the carb be sure to check slide movement manually.

3. Remove the stock main jets and replace with the Cobra main jets provided. If you are running the Classic style exhaust or Drag pipes with baffles install the DJ170 main jet in the front cylinder carb and the DJ175 main jet in the rear cylinder carb. When running Drag pipes without baffles install the DJ175 in the front cylinder carb and the DJ180 in the rear cylinder carb. Be sure that the jet you are changing is the main jet.

4. Locate the fuel mixture plug (Fig. B). If you see a screw head at Fig. B proceed to the adjusting procedure. With the 5/32 drill bit provided, carefully drill through the plugs. **NOTE:** The mixture screw is directly underneath this plug, be ready to pull back on the drill the instant you break through. Use screw provided to secure and remove this plug. Carefully turn mixture screws clockwise until lightly seated, then turn out 2 3/4 turns.

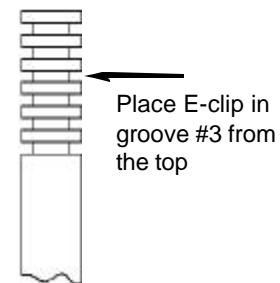

Fig. A

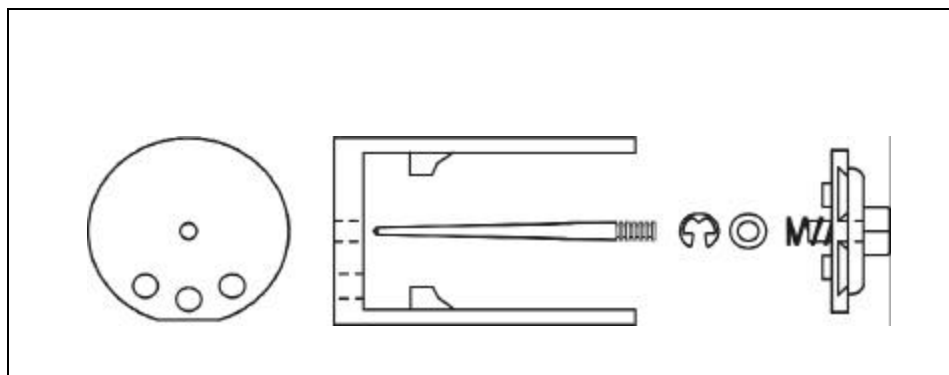

Fig. B

