



Items Supplied >

- 1 – RIGHT MUFFLER ASSEMBLY
- 1 – LEFT MUFFLER ASSEMBLY
- 2 – CLAMP, 27-61MSC

Application >

HARLEY:  
 DRESSER 1995 - 2016

Instruction Manual >

6212

Page 1 of 1

Qualified Manufacturer Declared Emissions Replacement Part on models not originally equipped with mufflers containing catalyst. Applicable Harley-Davidson® FL Touring Models listed below:  
 California FL Touring Models: Fuel Injected MY 1995-2003, 2007 and 2009-2016; CVO MY 2000-2003 and 2009-2016  
 49 State FL Touring Models: Carbureted MY 1995-2005; Fuel Injected MY 1995-2005 and 2007-2016;  
 CVO MY 2000-2005 and 2009-2016.

**Read all instructions carefully and completely before installing your new slip-on mufflers.**

1. Remove the saddlebags carefully.
2. Remove and save the mounting hardware securing the mufflers to the brackets. Loosen the stock muffler clamps then pull the stock mufflers free from the headpipes. The stock clamps will not be reused.
3. Slide the supplied 27-61MSC clamps over the slip-on mufflers and position them as shown in Figure 1 with the hex head facing inward and towards the ground.
4. Slide the mufflers onto the headpipes until the mounting holes align. Note: Indents on mufflers will face inward. Fasten the mufflers using the stock mounting hardware in the same manner as stock but **do not tighten**.
5. From the rear, rotate the mufflers as needed so they are level with the ground and parallel with each other.
6. Verify that the gap, where the mufflers meet the stock heatshields, is similar to the gap the stock mufflers allotted.
7. Check all clearances and alignments then tighten the mounting bolts to factory specifications. Tighten the muffler clamps. (NOTE: The muffler clamps should be flush with the end of the muffler when tightened. See **Figure 2**. If the muffler clamps are slid past the slots on the slip collar the clamps will not tighten the mufflers properly).
8. Reinstall saddlebags carefully.
9. **IMPORTANT: Before starting your engine remove all fingerprints from chrome with a quality wax or chrome polish. Failure to do so can cause chrome discoloration. Due to fluctuations in fuel delivery settings, timing, etc., Cobra Engineering does not warrant against chrome discoloration. Clean exhaust residue from the exhaust tips with a microfiber cloth and WD-40.**

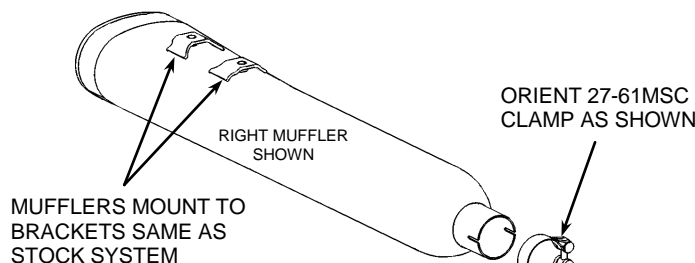

FIGURE 1

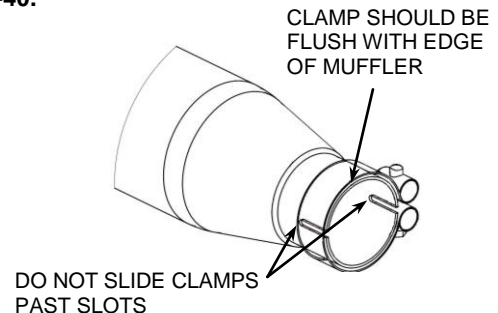

FIGURE 2

**NOTE: Upon initial start up of motorcycle with new exhaust installed some smoke will appear for a short period, this is normal and is the internal material breaking in.**

DISCLAIMER: NOT LEGAL FOR SALE OR USE IN CALIFORNIA ON ANY POLLUTION CONTROLLED MOTOR VEHICLE. THE SALE, USE, OR INSTALLATION OF THIS PRODUCT MAY ALSO BE ILLEGAL NATIONWIDE UNDER THE FEDERAL CLEAN AIR ACT (42 U.S.C. § 7522(A)(3)).