



**Items Supplied >**

- 1 – INTAKE COVER W/ INTAKE SCREEN ASSEMBLY
- 1 – VENTURI AIR FILTER
- 1 – MOUNTING PLATE
- 1 – BILLET VELOCITY STACK
- 2 – INTAKE GASKET
- 2 – BREATHER BOLT, 3/8"-16 X 1" W/ TEFLON SEALANT
- 3 – BOLT, 1/4"-20 X 1-1/8", BUTTONHEAD W/ LOCK PATCH
- 3 – LOCK WASHER, 1/4" TOOTHED
- 3 – BOLT, 1/4"-20 X 5/8", HEX FLANGE

**Application(s) >**

HARLEY:  
ALL SOFTTAILS WITH 107 CI MOTOR 18-22

**NOTE:** WILL NOT FIT SOFTTAILS WITH 114 CI MOTORS.

**Instruction Manual >**

606-0104-SB

Page 1 of 3

**Read all instructions carefully and completely before installing your new air intake.**

1. Remove the stock air cleaner cover. Remove the (3) bolts securing the filter to the throttle body and remove the filter and breather hose assembly. Save the stock breather hose assembly as this will be reused. Remove the two breather bolts from the cylinders and remove the back cover.
2. Install the supplied breather bolts into the cylinders. See **FIGURE 1**. Tighten securely.
3. Insert the center hose of the stock breather hose assembly through the left hole in the supplied mounting plate and then through the velocity stack so that the hose is in the center of the velocity stack. See **FIGURE 1 & 2**.
4. While holding that assembly together with one hand, Insert the (3) supplied 1/4"-20 x 1-1/8" buttonhead bolts and lock washers through the mounting holes in the velocity stack and mounting plate. See **FIGURE 1**.
5. Then align the supplied gaskets and spacer so the notch is to the bottom left and slide them over the (3) bolts onto the backside of the mounting plate. Make sure there is a gasket on both sides of the spacer. See **FIGURE 1**.
6. Align all the components with the throttle body and start threading the (3) buttonhead bolts into the throttle body. Tighten the three bolts evenly making sure the inner diameter of the velocity stack, gaskets, and spacer align with the inner diameter of the throttle body.
7. Attach the stock breather hoses to the breather bolts in the cylinder head. The front hose has to go behind the mounting plate to be attached to the breather bolt.
8. Place the supplied air filter onto the velocity stack. See **FIGURE 3**.
9. Insert the intake screen assembly into the POWRFLO™ intake cover so the holes in the bent tabs align with the threaded bosses. See **FIGURE 3**.
10. Place the intake cover over the air filter and align threaded bosses with the mounting plate holes. Insert the (3) supplied 1/4"-20 x 5/8" hex flange bolts through the mounting plate, intake screen and into the intake cover then tighten. See **FIGURE 3**.
11. Verify all the bolts are tight and then wipe off any fingerprints with a clean microfiber cloth.

**CONTINUED ON PAGE 2**

DISCLAIMER: NOT LEGAL FOR SALE OR USE IN CALIFORNIA ON ANY POLLUTION CONTROLLED MOTOR VEHICLE. THE SALE, USE, OR INSTALLATION OF THIS PRODUCT MAY ALSO BE ILLEGAL NATIONWIDE UNDER THE FEDERAL CLEAN AIR ACT (42 U.S.C. § 7522(A)(3)).

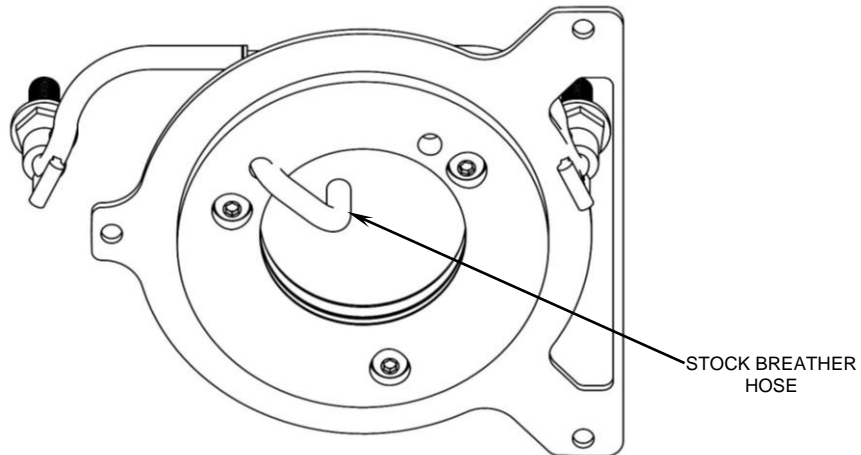
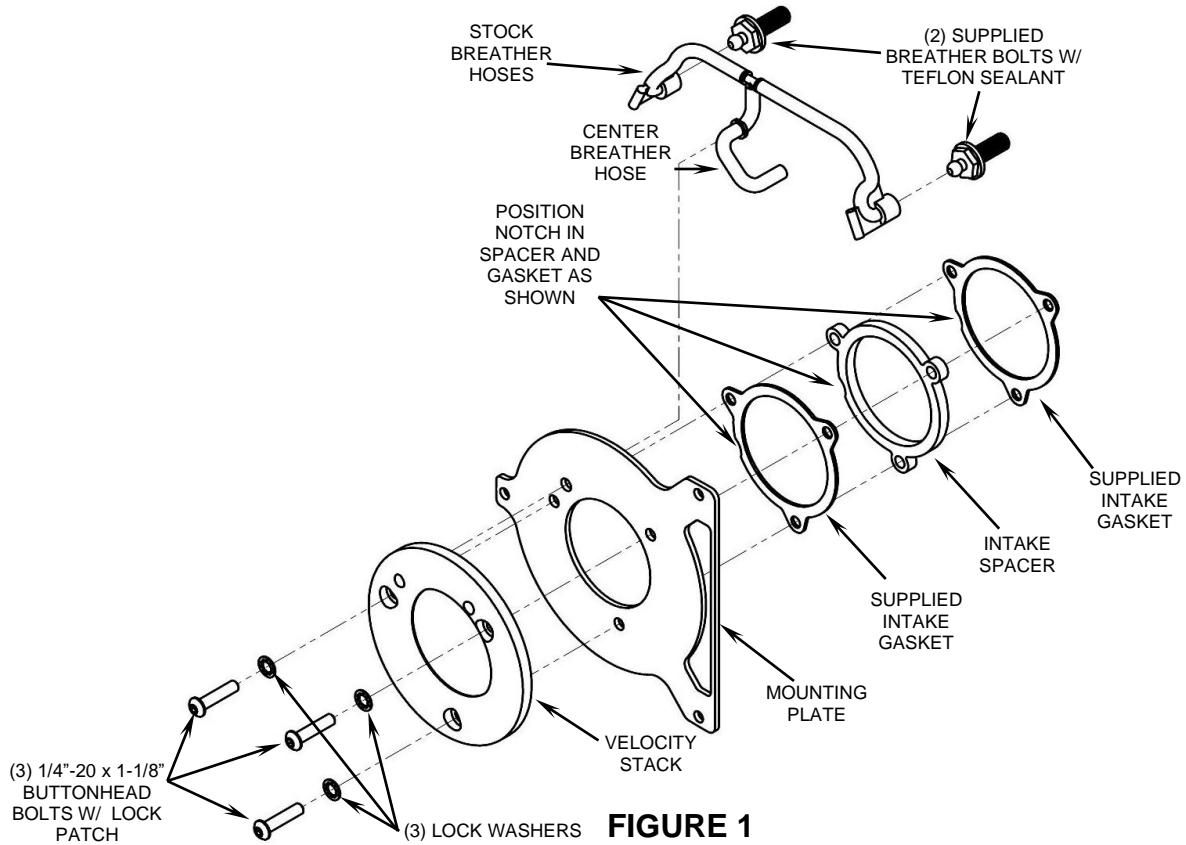

CONTINUED ON PAGE 3

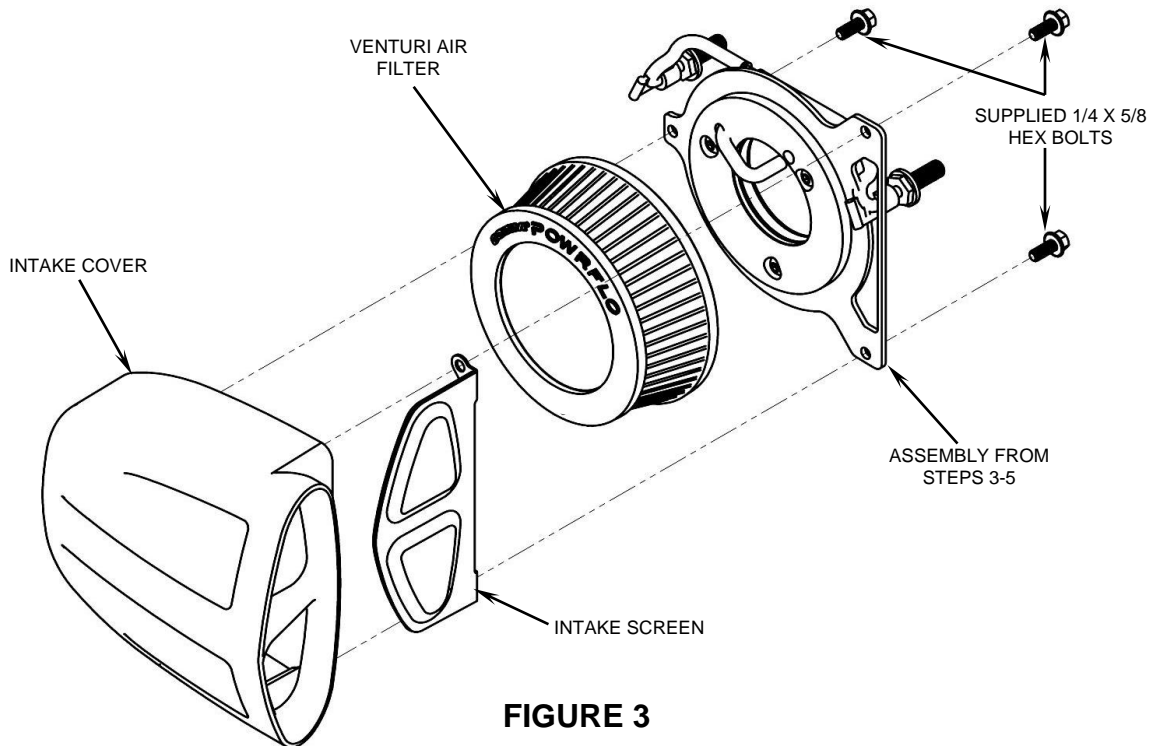

**DISCLAIMER: NOT LEGAL FOR SALE OR USE IN CALIFORNIA ON ANY POLLUTION CONTROLLED MOTOR VEHICLES.**

DOCUMENT NO. 0018 REV. B