

Items Supplied >

- 1 - FRONT EXHAUST ASSEMBLY W/ FLANGE
- 1 - REAR EXHAUST ASSEMBLY W/ FLANGE
- 2 - HEATSHIELDS
- 1 - EXHAUST MOUNT BRACKET
- 2 - BILLET MUFFLER TIPS
- 5 - HOSE CLAMP HS-24
- 2 - HOSE CLAMP HS-28
- 2 - BOLT, M10-1.25 X 35mm, HEX FLANGE
- 4 - BOLT, 5/16" X 5/8" HEX FLANGE
- 2 - BOLT, 1/4" X 3/8" BUTTONHEAD
- 1 - WIRE HARNESS, O₂ SENSOR

Application(s) >

YAMAHA STRYKER 2011-2013

Instruction Manual >

2630

Page 1 of 2

PRIOR TO INSTALLATION, MAKE SURE YOUR STOCK HEADPIPE GASKETS ARE IN GOOD SHAPE. IF YOU HAVE ANY DOUBTS AS TO THEIR CONDITION, REPLACE THEM.

Read all instructions carefully and completely before installing your new exhaust system

1. Loosen the right footpeg assembly to help provide clearance for exhaust removal and installation.
2. Remove the small plastic cover located behind the rear headpipe and disconnect the O₂ sensor connector. (NOTE: Push-in the center pin on the fastener to release plastic cover).
3. Remove the stock exhaust system and stock exhaust mount. Save the (4) acorn nuts that attach the headpipes flanges to the cylinders, and exhaust gaskets for later use during installation.
4. Install the supplied exhaust mount bracket using the (2) supplied M10 x 35mm hex flange bolts, but **DO NOT FULLY TIGHTEN**. See Figure 1.
5. Install the stock O₂ sensor into the O₂ sensor bung on the supplied front exhaust assembly, and tighten it securely. Install the front exhaust assembly to the front cylinder using the stock acorn nuts removed in Step 3, but **DO NOT TIGHTEN**. Make sure exhaust gasket remains in place. Align muffler with mounting holes in the exhaust mount bracket and insert (2) supplied 5/16"-18 x 5/8" hex flange bolts but **DO NOT TIGHTEN**.

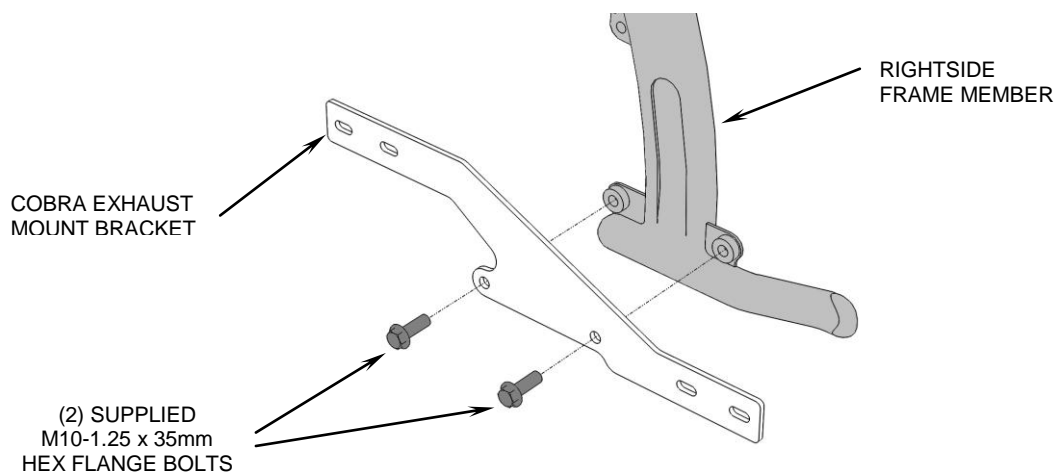

FIGURE 1

*** Cobra® recommends you always wear a helmet while riding. Please never operate your motorcycle while under the influence of alcohol and/or drugs. Enjoy the new look of your motorcycle and please ride safely.**

6. Install the rear exhaust assembly to the rear cylinder using the stock acorn nuts removed in Step 3, but **DO NOT TIGHTEN**. Make sure exhaust gasket remains in place. Align muffler with mounting holes in the exhaust mount bracket and insert (2) supplied 5/16"-18 x 5/8" hex flange bolts but **DO NOT TIGHTEN**.
7. Make sure the front and rear exhaust assemblies are parallel to each other then tighten the following in order, exhaust bracket to the frame, headpipe flanges to the motor (slowly tighten opposing nuts), and exhaust assemblies to the exhaust bracket.
8. Plug O₂ sensor connector into the supplied O₂ sensor harness extension and plug the opposite end into the stock harness location. Make sure the extension harness is tucked away from exhaust system. Reinstall small plastic cover and fastener (NOTE: push pin out, install, then push pin flush).
9. On the front and rear heatshields, unscrew the hose clamps and feed the tail end of the clamp through the clips on the inside. The larger clamps are to be placed at the rear of the heatshield so they clamp over the mufflers. The screw end of the hose clamps should be accessible for tightening but not visible when the heatshields are mounted to the pipes. See Figure 2.
10. To install the front heatshield, first slide the rear portion of the heatshield over the muffler, continue to slowly slide it forward pushing the front of the shield gently into place between the frame and motor (Hint: Spread the hose clamps apart slightly to make it easier to slide them over the muffler assembly and headpipes). Snug the heatshield clamps but **DO NOT TIGHTEN**. Repeat for rear heatshield.
11. Make sure the front and rear heatshields are parallel with each other. Install one billet tip on each heatshield. Fasten the tips with the (2) supplied 1/4"-20 x 3/8" buttonhead bolts making sure they snug up against the heatshield leaving no gap between the tip and heatshield when tightened. **If it is difficult to slide the tips into the heatshields, loosen the clamps on the heatshield, failure to do this may cause damage to the chrome tips.**
12. Tighten the clamps on the heatshields.
13. Reinstall footpeg assembly with the stock bolts and tighten.
14. Make sure all the hardware (brackets, headpipes, heatshields, mufflers and baffles) has been tightened appropriately and cleaned before starting your motorcycle.

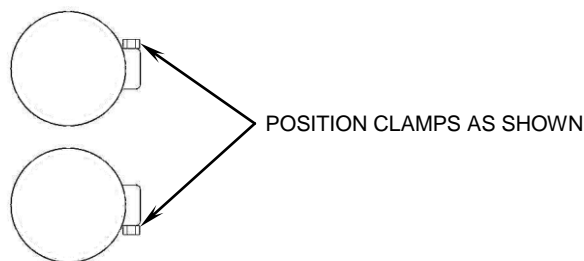

FIGURE 2
FRONT VIEW

IMPORTANT: Cobra highly recommends using a Fi2000® Fuel Management System to help eliminate lean conditions, poor drivability or poor throttle response. (Cobra Part# 92-1770AT or 92-1770CL for 49 state models and Part# 92-1770CL-50 for CA models.)

- * Before starting your engine remove all fingerprints from chrome with a quality wax or chrome polish. Failure to do so can cause discoloration. Due to fluctuations in fuel settings, timing, etc., Cobra Engineering does not warrant against chrome discoloration.

California does not allow the use of aftermarket exhaust systems that remove original equipment catalyysts, (except for racing use only) unless the Air Resources Board has issued an Executive Order for that system.