

Items Supplied >

1 – FRONT HEADPIPE W/HEATSHIELD
1 – REAR HEADPIPE W/HEATSHIELD
1 – MUFFLER ASSEMBLY
1 – EXHAUST-MOUNTING BRACKET
2 – EXHAUST FLANGES
5 – HOSE CLAMPS HS-24
4 – HOSE CLAMPS HS-28
2 – CLAMP, 27-61MSC
2 – BOLT, HEX 5/16-18 x 5/8

Application(s) >

YAMAHA RAIDER 2008-2018

Instruction Manual >

2225B

Page 1 of 3

PRIOR TO INSTALLATION, MAKE SURE YOUR STOCK HEADPIPE GASKETS ARE IN GOOD SHAPE. IF YOU HAVE ANY DOUBTS AS TO THEIR CONDITION, REPLACE THEM.

Read all instructions carefully and completely before installing your new exhaust system

1. Loosen and move the right side footpeg mount out of the way to ease removal of the stock exhaust and aid installation of the new Cobra exhaust.
2. Remove the seat by using the key.
3. Remove the (5) M6 Socket Head Screws retaining the chrome heatshield cover on the stock exhaust, see Figure 1, to gain access to the exhaust power valve assembly.
4. Disconnect the cables connected to the power valve by loosening the jam nuts to create slack in the cable, allowing the barrel end of the cable to become free from the rotary head, see Figure 2
5. Locate the oxygen sensor on the muffler body near the power valve and trace the wire on it back up to under the seat, where it's male and female connectors are located. Move the fuse block out of the way, by depressing the plastic tab between the housing and the steel-mounting tab, and pull it upward out of the way to gain access to the oxygen sensor connectors mounted on the plastic tab. Disconnect the oxygen sensor by pulling the tab on the female connector outward and pulling the male connector towards the front of the bike. The female part of this connector must also be freed from its mounting location by depressing the plastic mounting tab that secures it on its plastic mount, see Figure 3. This may be done with a small flat blade screwdriver accessed from under the rear fender, pull the connector rearward to free it. Once this female connector is free, pull it rearward and downward towards the rear of the bike.
6. Remove the stock upper rear exhaust-mounting bracket secured by (1) M8 buttonhead screw, and (2) M8 hex head flange bolts. Remove the front, and rear flange nuts securing the exhaust headpipes to the engine, retain all pieces for later use during reassembly of Cobra exhaust.
7. Now obtain aid to hold the stock exhaust in place and remove the two M10 Flange bolts securing the exhaust at the lower bracket. Remove the stock exhaust by rotating the entire assembly upward and forward to free it from the exhaust port studs. Once the exhaust is removed, remove the oxygen sensor for later reinstallation in the Cobra exhaust.
8. Remove the actuator cables from the control box by pulling the sheathing out of the retainers and sliding the cable barrels free from the rotating pulley, see Figure 4. Leave the actuator box in place and connected so the engine ECU will properly function without error codes.
9. Install the supplied Cobra exhaust mount using the original M10 bolts removed in Step 7, see Figure 5. **DO NOT TIGHTEN AT THIS TIME.**

** Cobra® recommends you always wear a helmet while riding. Please never operate your motorcycle while under the influence of alcohol and/or drugs. Enjoy the new look of your motorcycle and please ride safely.*

10. Install the front and rear headpipes onto the motorcycle using the supplied flanges, stock bolts and nuts. NOTE: On the rear headpipe be sure to install the stock flange cover as shown in Figure 6. Make sure the pipes are parallel to each other. **DO NOT TIGHTEN.**
11. Remove the muffler assembly from the box and install the oxygen sensor removed in Step 7, in the tapped bung, torque to factory specifications. Slide two supplied 27-61MSC clamps onto the front of the muffler body tubes. Refer to Figure 7 for alignment of the clamps.
12. Slide the muffler assembly onto the headpipes by tapping on the headpipes with your hand as you push the mufflers forward making sure the assembly slides as far forward as possible. Secure the muffler assembly to the mounting bracket using the supplied 5/16-18 bolts but **DO NOT TIGHTEN.**
13. Route the oxygen sensor connector and wire behind the frame rail and above the swingarm below the rear fender. Reconnect it with the female connector it was previously detached from.
14. Make sure the front of the muffler assembly is parallel to the headpipes (this is critical) then tighten the following in order, muffler mounting bracket to frame, muffler assembly to the muffler bracket, headpipe flanges to the motor (slowly tighten opposing nut) and muffler clamps. (NOTE: If the muffler clamps are slid to far up the muffler or past the two slots, the clamps will not tighten.)
15. Unscrew the supplied hose clamps and feed the tail end of the clamp through the clips on the inside of the heatshields. The screw end of the hose clamp should be accessible for tightening but not visible when the heatshields are mounted to the pipes.
16. To install the front heatshield, first slide the rear portion of the heatshield over the muffler, continue to slowly slide it forward pushing the front of the heatshield gently into place between the frame and motor (Hint: Spread the hose clamps apart slightly to make it easier to slide them over the muffler assembly and headpipes). Make sure the muffler clamps don't interfere with the heatshields and are aligned as shown in Figure 7. Snug the heatshield clamps but **DO NOT TIGHTEN.**
17. Install the rear heatshield the same way as the front heatshield.
18. Tighten the clamps on the heatshields.
19. Retighten the footpeg mount loosened in Step 1 to factory specifications.
20. Make sure all the hardware (brackets, headpipes, heatshields, mufflers and baffles) has been tightened appropriately and cleaned before starting your motorcycle.

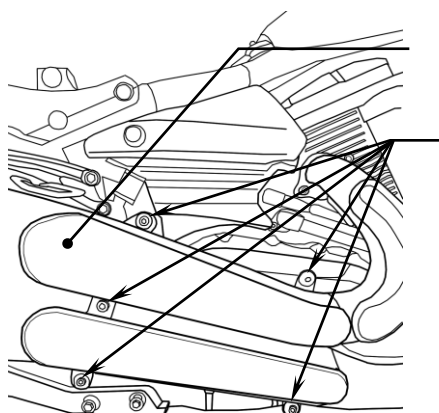

REMOVE HEATSHIELD FOR ACCESS TO POWER VALVE

REMOVE (5) M6 SOCKETHEAD SCREW

FIGURE 1

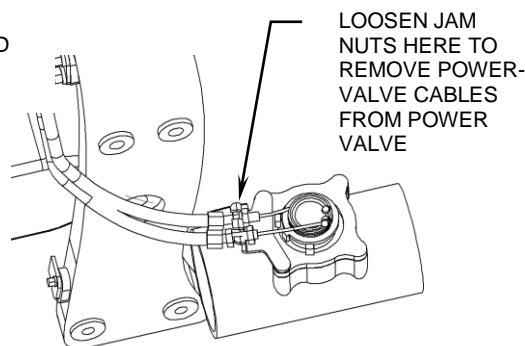

LOOSEN JAM NUTS HERE TO REMOVE POWER-VALVE CABLES FROM POWER VALVE

FIGURE 2

California does not allow the use of aftermarket exhaust systems that remove original equipment catalyts, (except for racing use only) unless the Air Resources Board has issued an Executive Order for that system.

DEPRESS TAB ON FUSE BOX HERE TO FREE FROM MOUNT

DEPRESS TAB HERE TO FREE FEMALE CONNECTOR BY ACCESSING FROM UNDER REAR FENDER WITH FLAT BLADE SCREWDRIVER

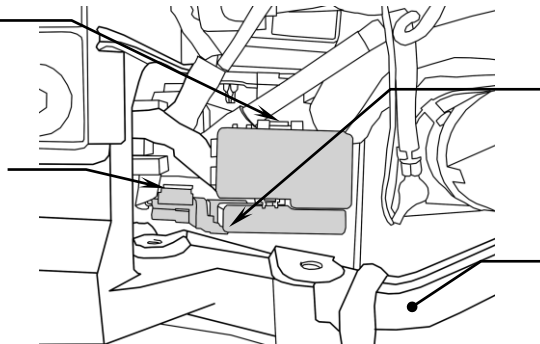

DISCONNECT MALE O2 SENSOR CONNECTOR FROM FEMALE CONNECTOR HERE

RIGHT SIDE FRAME RAIL

FIGURE 3

CABLE BARRELS CONNECTED AT ACTUATOR PULLEY

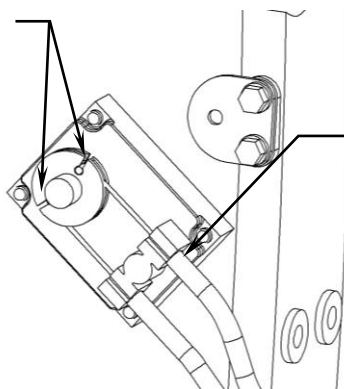
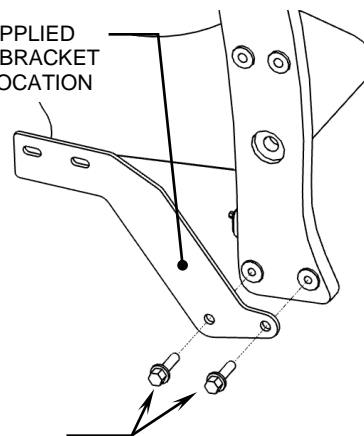

FIGURE 4

INSTALL SUPPLIED MOUNTING BRACKET IN STOCK LOCATION



STOCK M10 BOLTS

FIGURE 5

ASSEMBLY ORDER OF REAR EXHAUST HEADPIPE AND COMPONENTS:

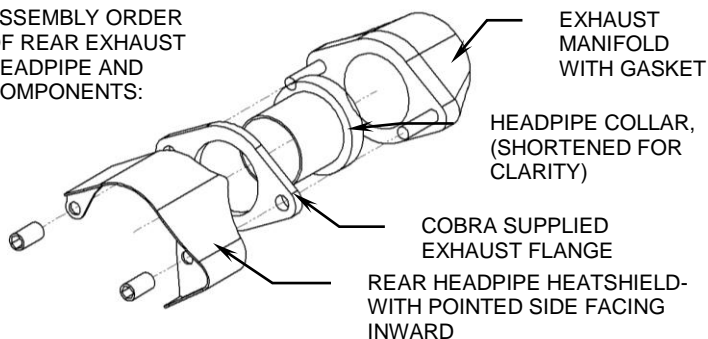

FIGURE 6

EXHAUST MANIFOLD WITH GASKET

HEADPIPE COLLAR, (SHORTENED FOR CLARITY)

COBRA SUPPLIED EXHAUST FLANGE

REAR HEADPIPE HEATSHIELD- WITH POINTED SIDE FACING INWARD

ORIENTATE CLAMPS AS SHOWN

FRONT VIEW

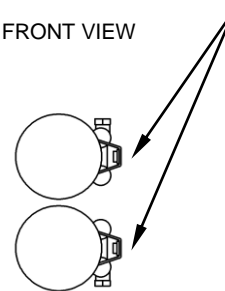

FIGURE 7

IMPORTANT: Cobra highly recommends using a Fi2000® Fuel Management System to help eliminate lean conditions and popping sounds. Cobra Part # 92-1777CL for Fi2000 closed loop 49 State models and for California Models, Cobra Part # 92-1777CL-50 should be used.

CLEANING INSTRUCTIONS:

To clean your black exhaust system use a liquid based soap detergent, such as dishwashing soap applied with a soft cloth and rinse with clean water. Note: Avoid abrasive cleaning methods such as granular or dry cleansers, simple green, scotch-brite or steel wool pads. Abrasives may breach the coating and shorten life.