

Items Supplied >

2 – FRONT & REAR EXHAUST HEADPIPE
2 – FRONT & REAR EXHAUST HEATSHIELD
1 – MUFFLER ASSEMBLY
1 – EXHAUST BRACKET
4 – CLAMPS, HS-24
2 – CLAMPS, HS-28
2 – CLAMP, 27-59MSC
2 – BOLT, HEX 5/16-18 x 5/8"
2 – SCREW, BUTTON ¼-20 x 3/8"
2 – BILLET MUFFLER TIPS

Application(s) >

Honda Spirit 750 C2	2007-14
Honda Aero 750	2008-16
Honda Phantom 750	2010-19*

Instruction Manual >

1711 / 1911

Page 1 of 2

PRIOR TO INSTALLATION, MAKE SURE YOUR STOCK HEADPIPE GASKETS ARE IN GOOD SHAPE. IF YOU HAVE ANY DOUBTS AS TO THEIR CONDITION, REPLACE THEM.

Read all instructions carefully and completely before installing your new exhaust system

1. Remove stock exhaust system but do not remove the large stock muffler mount.
2. Loosen and move the rider right footpeg assembly out of the way to ease installation of the exhaust.
3. Remove the exhaust mount bracket from the box and mount it to the motorcycle mount bar using the stock nuts but **DO NOT TIGHTEN** at this time. (See Figure 1)
4. Install the front and rear head pipes onto motorcycle using the stock acorn nuts but **do not tighten**.
5. Slide one supplied clamp onto each muffler and position as shown in figure 2.
6. Slide the muffler assembly onto the head pipes. Secure the muffler assembly to the mounting bracket using the supplied 5/16-18 bolts but **DO NOT TIGHTEN** at this time. **Note:** Position the bolts in the middle of the slots on the mount bracket.
7. Make sure the muffler assembly is parallel to the ground then tighten the following in order, muffler bracket to the frame, head pipe flanges to the motor (slowly tighten opposing nut) and muffler clamps, and muffler assembly to the muffler bracket. (NOTE: If the muffler clamps are slid to far up the muffler or past the three slots, the clamps will not tighten.)
8. Unscrew the remaining hose clamps and feed the tail end of the clamp through the clips on the inside of the heatshields. The screw end of the hose clamp should be accessible for tightening but not visible when the heat shields are mounted to the pipes. Note: the smaller muffler clamps go around the headpipes the larger ones around the muffler.
9. To install the front heatshield, first slide the rear portion of the heatshield over the muffler, continue to slowly slide it forward pushing the front of the shield gently into place between the frame and motor (Hint: Spread the hose clamps apart slightly to make it easier to slide them over the muffler assembly and head pipes). Make sure the muffler clamps do not interfere with the heatshields and are aligned as shown in Figure 2. Snug the heatshield clamps but **do not tighten**.

California does not allow the use of aftermarket exhaust systems that remove original equipment catalysts, (except for racing use only) unless the Air Resources Board has issued an Executive Order for that system.

*** Cobra® recommends you always wear a helmet while riding. Please never operate your motorcycle while under the influence of alcohol and/or drugs. Enjoy the new look of your motorcycle and please ride safely.**

10. Install the rear heatshield the same way as the front heatshield.
11. Make sure the front and rear heatshields are even on the back with each other. Install one billet tip on each heatshield. On Slashdown models install one billet tip on each heatshield making sure the angled ends of the tips are parallel with each other. Fasten the tips with the supplied $\frac{1}{4}$ -20 screws making sure they snug up against the heatshield leaving no gap between the tip and heatshield when tightened. **If it is difficult to slide the tips into the heatshields loosen the clamps on the heatshield, failure to do this may cause damage to the chrome tips.**
12. Tighten clamps on heatshields.
13. Reinstall the rider right footpeg assembly and tighten bolts to factory specifications.
14. Make sure all hardware is tight before starting your motorcycle.

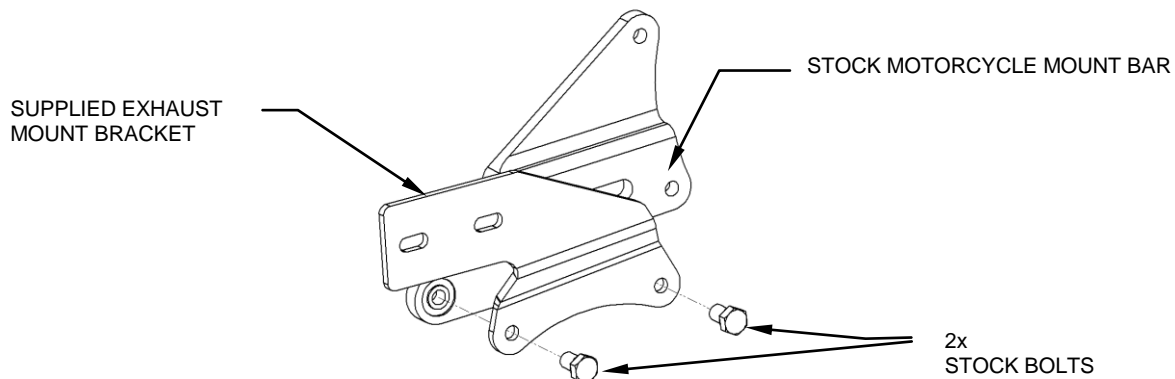
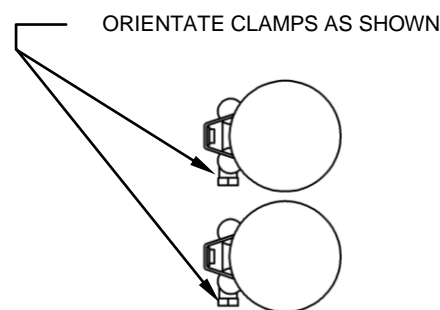

FIGURE 1



REAR VIEW
FIGURE 2

Important: It is recommended that you re-jet your bike with a Cobra Jet Kit, part #92-1281 for Spirit 750 C2, and part #92-1263 for Aero 750. Jet Kits are not legal for sale or use in California on any pollution controlled motor vehicles. For the 2010 Phantom a Cobra Fi2000® Digital Fuel Processor is recommended, part #92-1619 and part #92-1619-50 for California models.

Before starting your engine remove all fingerprints from chrome with a quality wax or chrome polish. Failure to do so may cause discoloration.

California does not allow the use of aftermarket exhaust systems that remove original equipment catalyts, (except for racing use only) unless the Air Resources Board has issued an Executive Order for that system.