

## Items Supplied >

- 1 - INTAKE COVER W/ SCREEN ASSEMBLY
- 1 - VENTURI AIR FILTER
- 1 - BILLET VELOCITY STACK
- 1 - MOUNTING PLATE
- 1 - SUPPORT BRACKET; 1 - FUEL INJECTION COVER
- 2 - BOLT, M5 X 16mm, ALLEN; 1 - BOLT, M5 X 30mm, ALLEN
- 1 - BOLT, M6 X 12mm, ALLEN
- 4 - BOLT, 1/4"-20 X 1/2", BUTTONHEAD
- 3 - BOLT, 1/4"-20 X 5/8", FLANGED HEX
- 4 - WASHER, 1/4" INTERNAL TOOTH LOCK
- 1 - WASHER, M5 SPLIT LOCK
- 1 - O-RING, 1.25" I.D. X .125", BUNA-N (SMALL)
- 1 - O-RING, 3.25" I.D. X .125", BUNA-N (LARGE)

## Application(s) >

YAMAHA BOLT 950

2013 - 2019

## Instruction Manual >

06-0267B-SB

Page 1 of 2

Read all instructions carefully and completely before installing your new POWRFLO™ Intake.

1. Remove the (4) bolts that hold on the stock air cleaner cover. Remove the cover and filter from air box.
2. Remove the air box by loosening the (3) M5 allen bolts around the air inlet and (1) M6 on the right side of the housing, Figure 1. Disconnect the hose from the backside of the air box and remove it, the screws will not be reused.
3. Insert the supplied o-rings into the grooves of the supplied velocity stack. NOTE: Do not attempt to stretch o-rings into grooves; position o-rings evenly around groove and use gentle force (No tools) to push them in.
4. Bolt the velocity stack to the throttle body using the (2) supplied M5 x 16mm allen bolts and the (1) supplied M5 x 30mm allen bolt w/ split lock washer. Fully tighten. See Figure 2.
5. Position the mounting plate over the velocity stack (with the welded tube toward inside) and secure using (3) supplied 1/4"-20 x 1/2" buttonhead bolts and (3) internal tooth lock washers, finger tighten only. See Figure 3.
6. Install the supplied support bracket on to the stock bracket protruding from the top of the front cylinder head, secure finger tight with the supplied M6 x 12mm buttonhead bolt. Align the support bracket hole with the corresponding hole in the backing plate and secure with (1) 1/4"-20 x 1/2" buttonhead bolt and internal tooth lock washer. See Figure 3.

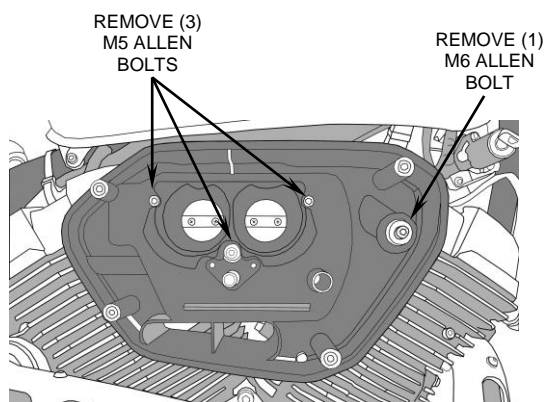
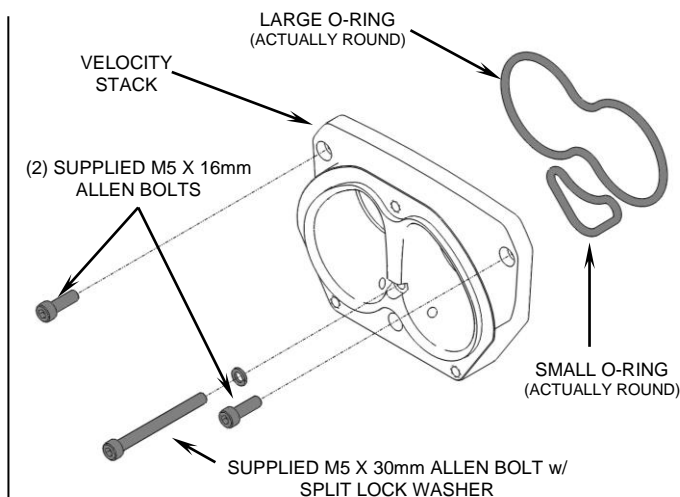
**FIGURE 1****FIGURE 2**

DISCLAIMER: NOT LEGAL FOR SALE OR USE IN CALIFORNIA ON ANY POLLUTION CONTROLLED MOTOR VEHICLE. THE SALE, USE, OR INSTALLATION OF THIS PRODUCT MAY ALSO BE ILLEGAL NATIONWIDE UNDER THE FEDERAL CLEAN AIR ACT (42 U.S.C. § 7522(A)(3)).

8. Attach the hose and hose clamp that was disconnected in Step 2 to the tube on the mounting plate.
9. Position the fuel injection cover behind the mounting plate as shown in Figure 3.
10. Insert the intake screen into place so the holes in the bent tabs align with the threaded bosses in the intake cover, see Figure 4 for orientation. Place the supplied venturi filter into the intake cover.

Place intake cover over the mounting plate and align the mounting holes to the threaded bosses. Insert the (3) supplied 1/4" hex flange bolts and tighten the mounting plate to the intake cover. See Figure 4.

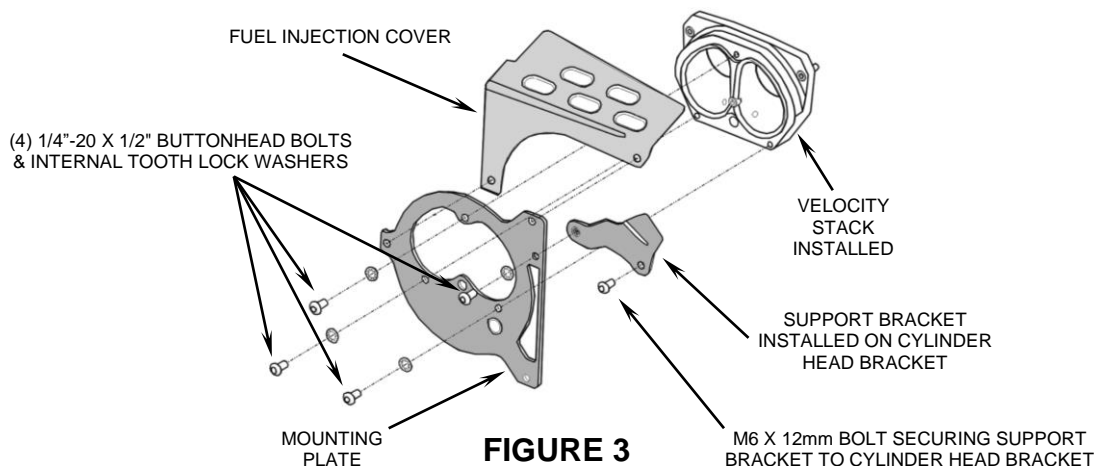

#### CLEANING INSTRUCTIONS:

To clean your black air intake system use a liquid based soap detergent, such as dishwashing soap applied with a soft cloth and rinse with clean water. Note: Avoid abrasive cleaning methods such as granular or dry cleansers, simple green, Scotch-Brite or steel wool pads. Abrasives may breach the coating and shorten life.

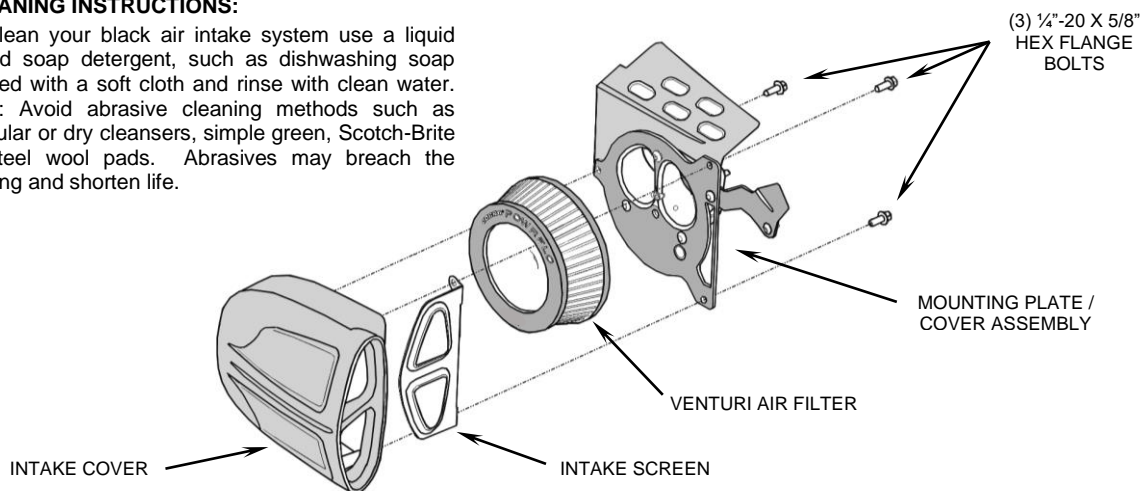

#### CALIFORNIA CUSTOMERS:

In California, aftermarket parts that have been identified specifically as replacement parts or that have received an Air Resources Board Executive Order may be used on street motorcycles. All other emissions related aftermarket parts are for competition use only. A list of replacement parts and EO parts, and corresponding fitment is provided at: [www.cobrausa.com](http://www.cobrausa.com)