

Items Supplied >

- 1 – INTAKE COVER W/ SCREEN / RING ASSEMBLY
- 1 – K&N® VENTURI AIR FILTER
- 1 – BILLET VELOCITY STACK
- 1 – MOUNTING PLATE
- 1 – FUEL INJECTOR COVER
- 1 – THROTTLE BODY SPACER
- 1 – SUPPORT BRACKET
- 3 – BOLT, 1/4"-20 X 1/2", BUTTONHEAD
- 1 – BOLT, 6mm X 16mm, BUTTONHEAD
- 4 – LOCK WASHER, 1/4" TOOTHED

Application(s) >

HONDA FURY	2010 - 2017
SABRE	2010 - 2014
STATELINE	2010 - 2016
INTERSTATE	2010 - 2015

Instruction Manual >

06-0133 - 01B/02B/03B/04B

Page 1 of 2

Read all instructions carefully and completely before installing your new POWRFLO™ Intake.

1. Remove the (4) bolts that hold on right side air cleaner cover. Remove chrome cover and filter from air box.
2. Remove the air box by loosening the (4) screws around the air inlet. Remove those screws from the cylindrical tabs on the air box. Then remove the (1) M6 hex bolt from the lower portion of the air box. See Figure 1. The air box needs to be pulled outward to remove it from the throttle body adapter.
3. On the backside of the throttle body adapter detach the two rubber hoses by squeezing the hose clamps with a pair of pliers and sliding them past the inlets on the throttle body adapter (plug the hoses if oil drips).
4. Using a phillips screw driver loosen the throttle body adapter hose clamp that secures the throttle body adapter to the throttle body. Remove the throttle body adapter leaving the clamp attached to it.
5. Using the (4) stock screws from Step 2 and supplied lock washers, bolt together the supplied velocity stack, mounting plate, throttle spacer to the throttle body adapter in the order shown in Figure 2. Note: Apply blue Loctite® removable strength (not supplied) to stock screws before bolting together.

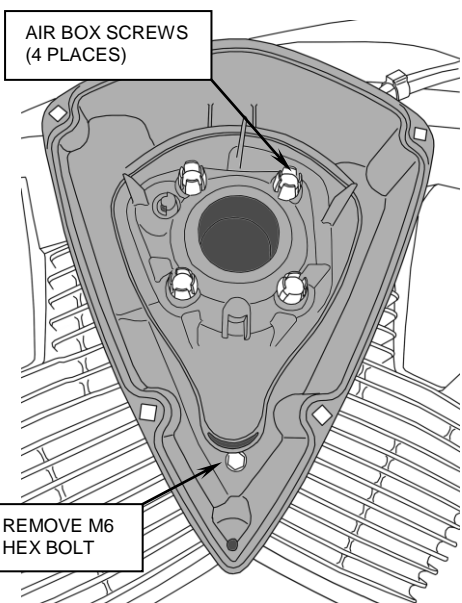

FIGURE 1

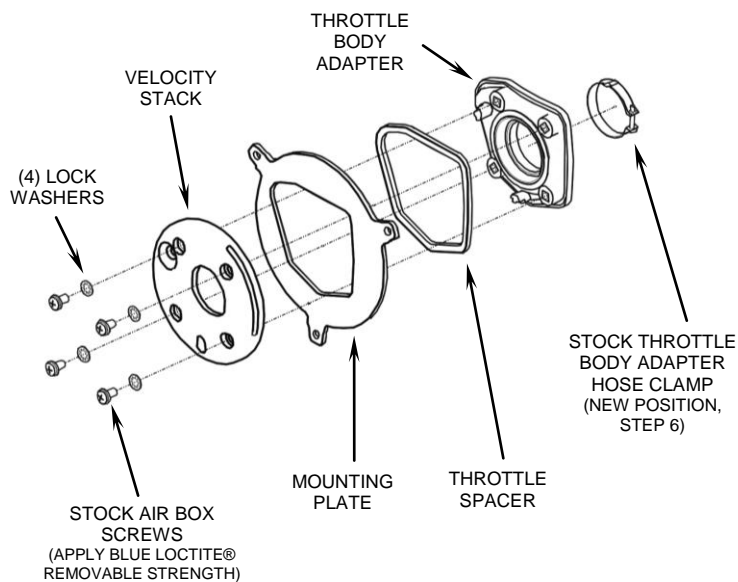

FIGURE 2

* *Cobra recommends you always wear a helmet while riding. Please never operate your motorcycle while under the influence of alcohol and/or drugs. Enjoy the new look of your motorcycle and please ride safely.*

6. Remove hose clamp from rubber seal on the backside of the throttle body adapter and flip 180 degrees then reinstall onto rubber seal, then rotate the clamp 90 degrees counter-clockwise so the screw is accessible from the lower front side of the motorcycle. See Figure 2. NOTE: the locating tab on the clamp will no longer be engaged; this is correct.
7. The mounting plate assembly is ready to be attached to the motorcycle. Reattach the hoses and hose clamps that were disconnected in Step 3, be sure any hoses that may have been temporarily plugged do not have anything still in them. Then engage the rubber seal of the throttle body adapter over the throttle body but leave the clamp loose for now.
8. Between the two cylinders is a bracket with a welded nut; align the slotted hole in the support bracket with that welded nut, then insert the (1) supplied M6 x 16mm buttonhead bolt and lightly snug tight.
9. Align and level the mounting plate assembly, make sure the support bracket upper hole is aligned to the bottom hole in the mounting plate then fully tighten the clamp over the throttle body adapter.
10. Place the supplied K&N® filter onto the velocity stack. Insert the round intake screen into the black ring so the screen sits inside the edge of the ring. Place the ring and screen between the legs of the naked black intake cover as shown in Figure 3.
11. Place the naked intake cover, ring and screen assembled in Step 10, over the air filter and align each leg to the mounting plate holes. Be sure screen sits at a 45 ° angle to the bottom leg, and C/V logo'd leg is at the upper left position. Insert (1) supplied 1/4"-20 x 1/2" buttonhead bolt through the lower leg of the intake cover and into the base mounting plate and into the support bracket threads, see Figure 3. Lightly snug to hold all parts in place.
12. Insert (2) supplied 1/4"-20 x 1/2" buttonhead bolts, into the upper legs of the naked intake cover, mounting plate and into the threaded holes of the fuel injector cover, Figure 3. Be sure the parts are all aligned and tighten all three 1/4"-20 x 1/2" and M6 x 16mm buttonhead bolts securing the naked cover to the mating parts. Be sure all clamps are tightened securely.

CLEANING INSTRUCTIONS:

To clean your black air intake system use a liquid based soap detergent, such as dishwashing soap applied with a soft cloth and rinse with clean water. Note: Avoid abrasive cleaning methods such as granular or dry cleansers, simple green, Scotch-Brite or steel wool pads. Abrasives may breach the coating and shorten life.

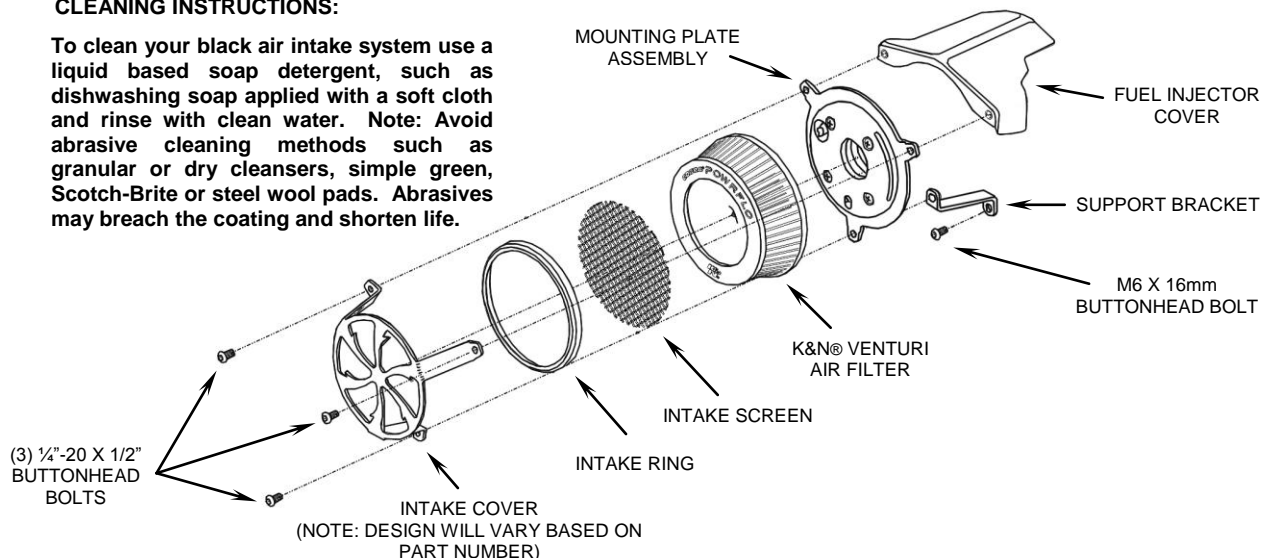

FIGURE 3

CALIFORNIA CUSTOMERS:

In California, aftermarket parts that have been identified specifically as replacement parts or that have received an Air Resources Board Executive Order may be used on street motorcycles. All other emissions related aftermarket parts are for competition use only. A list of replacement parts and EO parts, and corresponding fitment is provided at: www.cobrausa.com