

Items Supplied >

- 1 - INTAKE COVER
- 1 - K&N® VENTURI AIR FILTER
- 1 - INTAKE SCREEN ASSEMBLY
- 1 - BILLET VELOCITY STACK
- 1 - MOUNTING PLATE
- 1 - RUBBER INTAKE BOOT
- 1 - SUPPORT BRACKET
- 3 - BOLT, 1/4"-20 X 5/8", HEX FLANGE
- 2 - BOLT, 1/4"-20 X 5/8", BUTTONHEAD W/ LOCK PATCH
- 1 - BOLT, 1/4"-20 X 1/2", BUTTONHEAD
- 2 - BOLT, M6 X 20mm, BUTTONHEAD
- 2 - LOCK WASHER, 1/4" TOOTHED
- 2 - SPACER, ALUMINUM

Application(s) >

HONDA SHADOW RS 2010-2014

Instruction Manual >

06-0114

Page 1 of 2

Read all instructions carefully and completely before installing your new POWRFLO™ Intake.

1. Remove the (2) bolts that secure the stock air cleaner to the cylinder heads; these bolts and the steel bushings will not be reused.
2. On the backside of the air cleaner detach the two rubber hoses by squeezing the hose clamps with a pair of pliers and sliding them past the hose inlets (temporarily plug the hoses if oil drips).
3. Loosen the throttle body hose clamp on the backside of the air cleaner. Remove the air cleaner by pulling the rubber boot off the throttle body. Carefully rotate the air cleaner outwards from the bottom to disengage the intake snorkle that resides under the gas tank.
4. Using the (2) supplied 1/4"-20 X 5/8" buttonhead bolts and lock washers, assemble the velocity stack, mounting plate and rubber intake boot in the order shown in Figure 1. NOTE: The rubber boot lip needs to be sandwiched between the velocity stack and the mounting plate.
5. Remove the throttle body hose clamp from the stock boot and slide it onto the supplied rubber intake boot; position it as shown in Figure 1.
6. Attach the support bracket to the backside of the mounting plate using the (1) supplied 1/4"-20 X 1/2" buttonhead bolt, but do not fully tighten at this time. See Figure 2 for orientation.

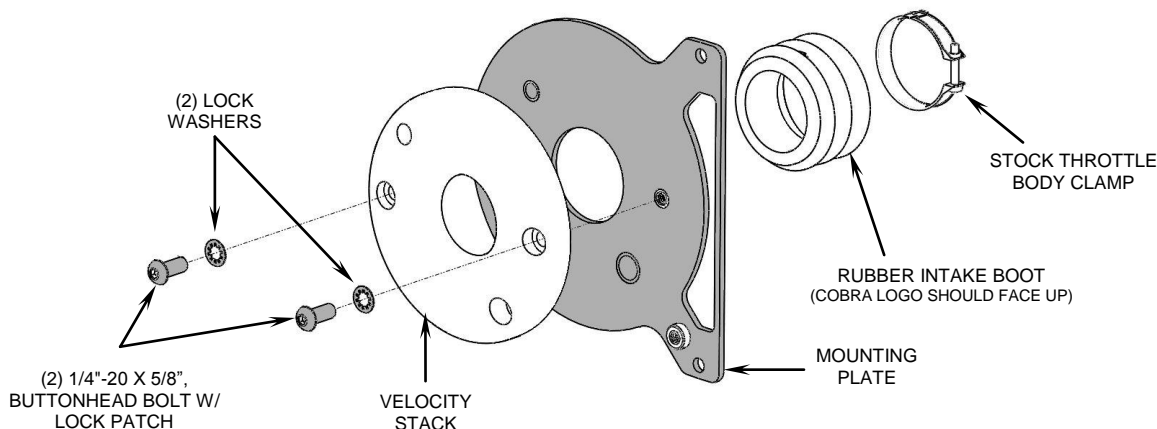

FIGURE 1

* Cobra® recommends you always wear a helmet while riding. Please never operate your motorcycle while under the influence of alcohol and/or drugs. Enjoy the new look of your motorcycle and please ride safely.

7. The mounting plate assembly is ready to be attached to the motorcycle. Attach the hoses and hose clamps that were disconnected in Step 2, to the inlet tubes on the mounting plate. Install the rubber boot onto the throttle body but leave the clamp loose for now.
8. Align the holes in the support bracket with threaded holes in the cylinder heads, then insert the (2) supplied M6 x 20mm buttonhead bolts through the support bracket, supplied spacers and into the cylinder heads. See Figure 2.
9. Align and level the mounting plate assembly so the air cleaner will sit straight, then fully tighten the clamp over the throttle body, then the bolt that secures the support bracket to the mounting plate, followed by the M6 bolts in the cylinders.
10. Place the supplied K&N® filter onto the velocity stack.
11. Remove the intake cover from the box and insert the intake screen into place so the holes in the bent tabs align with the threaded bosses in the intake cover.
12. Place intake cover over the mounting plate assembly and align the mounting holes to the threaded bosses. Insert the (3) supplied 1/4"-20 x 5/8" flange bolts and tighten the mounting plate to the intake cover. See Figure 3.

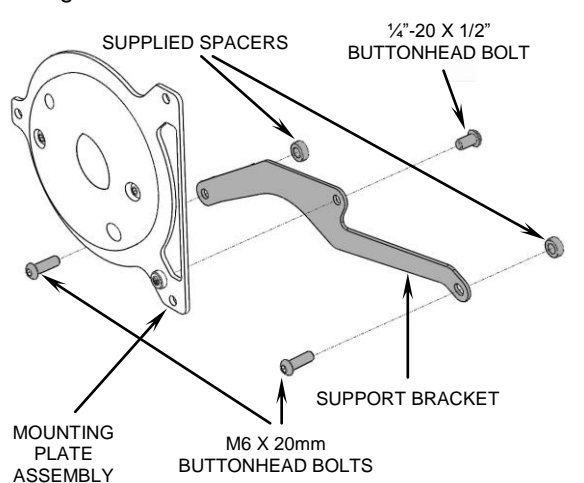

FIGURE 2

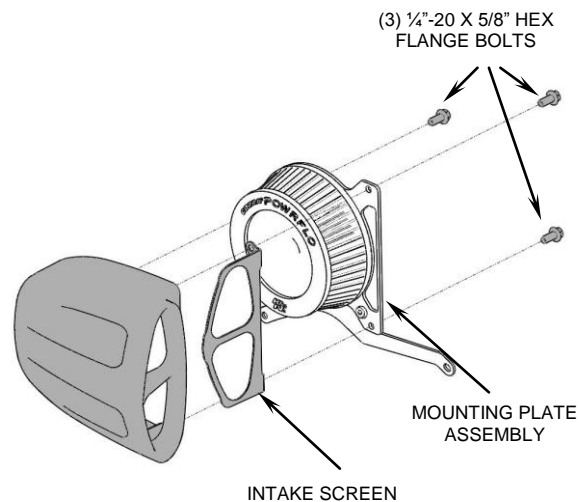

FIGURE 3

CALIFORNIA CUSTOMERS:

In California, aftermarket parts that have been identified specifically as replacement parts or that have received an Air Resources Board Executive Order may be used on street motorcycles. All other emissions related aftermarket parts are for competition use only. A list of replacement parts and EO parts, and corresponding fitment is provided at: www.cobrausa.com