

Items Supplied >

- 1 – Chrome Radiator Cover
- 2 – Screw, M6 X 30mm Buttonhead Stainless
- 2 – Spacer, Aluminum
- 1 – Adapter, Aluminum
- 1 – Washer M8

Application(s) >

Yamaha V-STAR 1300 2011-2014

Instruction Manual >

05-9350

Page 1 of 2

Read all instructions carefully before installing your new Cobra product!

1. Remove the (2) M6 buttonhead screws securing the stock radiator cover, these will not be reused.
2. Remove the rubber grommet from the plastic tab at the bottom of the stock plastic radiator cover, see Figure 1.
3. Place supplied M8 flat washer on the bottom side of the chrome cover and insert the stock grommet through the flat washer and hole in bottom of the chrome cover, Figure 2.
4. Insert the supplied M6 x 30 mm buttonhead screws through the chrome radiator cover's front-side at the top. Lay it on a flat surface face down, be sure to protect chrome from being scratched, Figure 3. Now place supplied aluminum spacers over protruding bolts on back of cover.
5. Install the stock plastic cover inside of the chrome cover with the screws protruding through it, Figure 4.
6. Insert the supplied aluminum adapter through the inner-side of plastic tab on the stock radiator cover and then through grommet in lower edge of chrome cover, Figure 5.
7. Take this assembly to motorcycle and rotate vertical in front of radiator. It may be necessary to have assistance to keep the buttonhead screws and spacers in place. Slide the aluminum adapter and entire cover

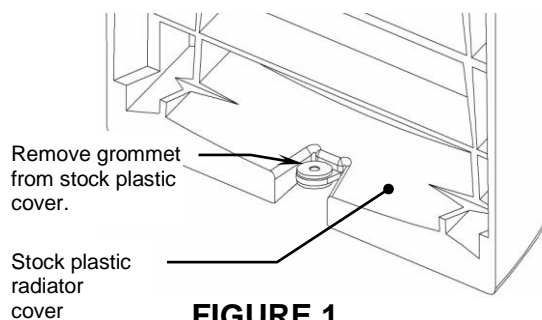

FIGURE 1

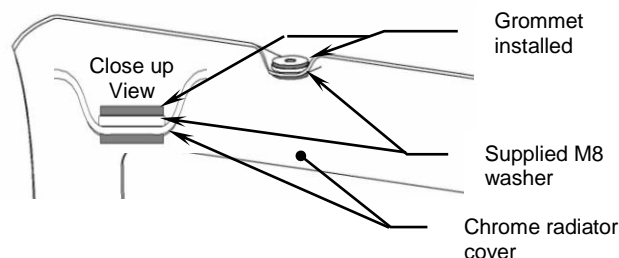

FIGURE 2

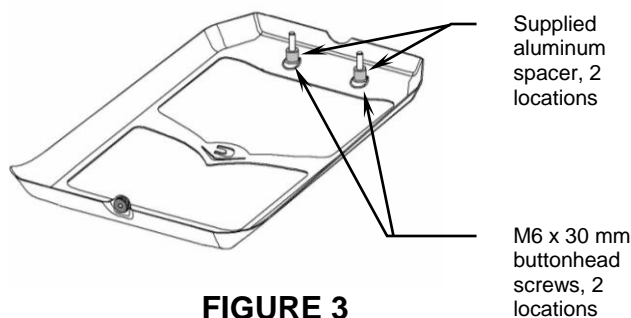
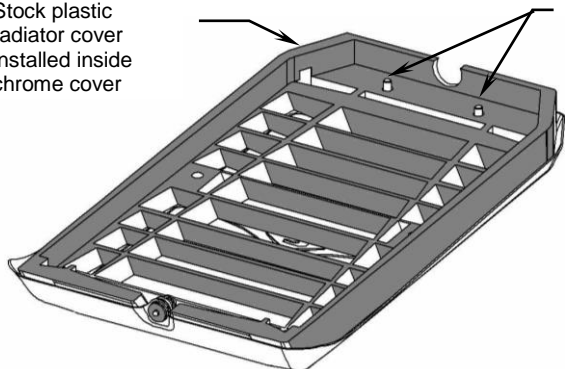

FIGURE 3

*** Cobra recommends you always wear a helmet while riding. Please never operate your motorcycle while under the influence of alcohol and/or drugs. Enjoy the new look of your motorcycle and please ride safely.**

8. Once plastic and chrome covers are centered between frame rails, screw buttonhead screws into tapped holes in top of radiator and tighten firmly, be sure aluminum spacers remain in place between chrome cover and plastic cover.

Stock plastic radiator cover installed inside chrome cover



M6 X 30mm
Screws protrude
through plastic
cover

FIGURE 4

Aluminum adapter inserted through plastic cover tab, grommet and Chrome cover / supplied washer

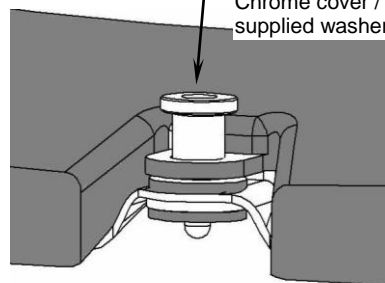
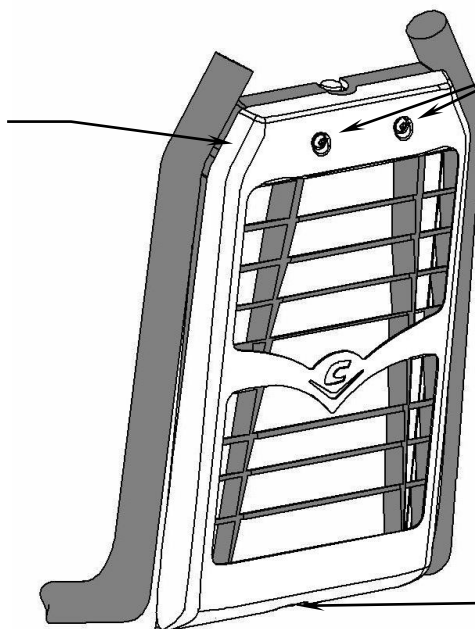

FIGURE 5

Be sure chrome radiator cover and stock plastic cover are centered between frame rails and then tighten buttonhead bolts



Tighten M6 X 30mm screws firmly to factory specifications

Aluminum adapter and covers slid over peg protruding from bottom of radiator

FIGURE 6

ATTENTION: Be sure to remove finger prints after installation with a quality chrome polish!

NOTE: If you have already installed a freeway bar, it may be necessary to remove it to allow installation of the radiator cover. Once you have installed the radiator cover reinstall the freeway bar and torque fasteners to factory specifications.