

Items Supplied >

- 1 – Lightbar Assembly
- 2 – Turn Signals, Left & Right
- 2 – 6mm X 20mm Hex Flange Bolt
- 2 – 1/4-20 x .500" Hex Flange Bolt
- 2 – Push On Terminal
- 1 – Black Power Wire W/Blue Quick Splice Connector
- 3 – Zip Ties

Application(s) >

KAWASAKI VN900 CUSTOM

07-19

Instruction Manual >

04-0467

Page 1 of 2

Read your installation instructions completely before beginning. This light bar can be installed in just a few minutes using common tools. It is recommended however, that a qualified mechanic or technician install this product.

1. Remove the new Cobra lightbar from packaging. Install the loose turn signals to the mounts with the (2) supplied 1/4" bolts; see Figure 1, page 2.
2. Remove (2) screws from motorcycle headlight and set aside. Remove the headlight from housing, unplug and set aside.
3. Locate left & right turn signal wires inside headlight housing and disconnect. Remove left and right turn signals from fork tubes. Note: remember which connectors inside the headlight housing are for left and right turn signal wires.
4. Install Cobra lightbar under bottom triple clamp by inserting the (2) supplied M6 x 20 flange bolts into the threaded holes in the lower triple clamp.
5. Align lightbar and main headlight housing then tighten according to factory torque specifications for an M6 bolt.
6. Rotate spotlights forward then align with main headlight and tighten.
7. Route the left & right turn signal harnesses through the back of the headlight housing and connect them back into the correct left and right turnsignal connectors.
8. Route the left spotlight wire under the lightbar towards the light bar switch, take right spotlight wire and twist together with the left one. Insert the two (twisted together) wires into the supplied push on terminal and crimp with a crimping tool. Connect this to one of the poles on the lightbar switch, it does not matter which one.
9. Connect the 20" **Black** power wire to the remaining pole on the lightbar switch. Route **Black** power wire through the back of the headlight housing. Loosely pull slack out of wire and using the 3 supplied zip ties wrap spotlight, turn signals, and power wire to the lightbar.
10. Locate the red/blue wire on either the left or right turn signal supply harnesses inside the headlight assembly. Connect the **Black** power wire from the lightbar switch to the red/blue wire using the supplied (blue) quick splice connector.
11. Reinstall headlight with (2) screws removed in Step 2.
12. Check to make sure your handlebars turn from lock to lock without any stretching or binding of any wires. Check the alignment of all your lighting. Make sure everything is in proper working order before riding the vehicle. **NOTE:** Figure 1 on next Page.

* **Cobra® recommends you always wear a helmet while riding. Please never operate your motorcycle while under the influence of alcohol and/or drugs. Enjoy the new look of your motorcycle and please ride safely.**

INSTRUCTIONS CONTINUED

CAUTION!
DO NOT PINCH
TURN SIGNAL WIRE
WHEN TIGHTENING
BOLT

RIGHT TURN
SIGNAL

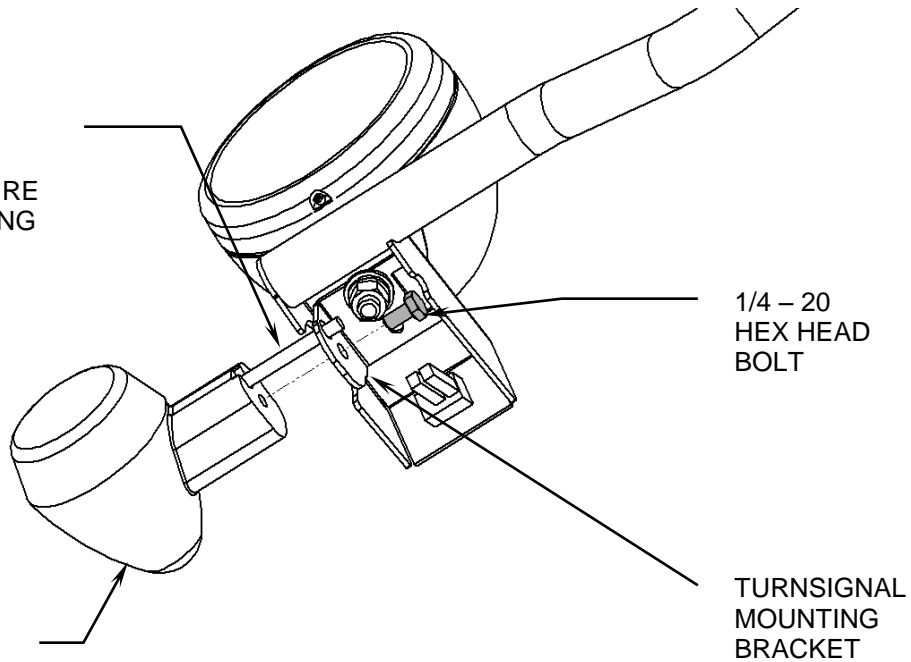

FIGURE 1