

Thank you for purchasing this Cobra Dynojet kit. This kit has been developed for a motorcycle which is set to the parameters listed at the right in the "Stage" description. If your motorcycle does not meet any of these parameters please check with Dynojet before installation. For technical assistance contact your Dynojet distributor or call Dynojet U.S.A. (800)-992-4993

Cobra Engineering
23801 E. La Palma Ave.
Yorba Linda, CA. 92887
TEL: 714-692-8180
FAX: 714-692-5016

Website Address
<http://www.dynojet.com>

The manufacturer and seller make no warranties express or implied which extend beyond the description of the goods contained herein. Any description of this product is for the purpose of identifying it and shall not be deemed to create an express warranty.

COBRA[®]
Anything's Possible

92-4166

U.S Models Only

1996-2004 Kawasaki VN1500 D&E

Vulcan Classic

Stage 1

For mildly tuned machines using the stock airbox, with stock filter and Cobra Boulevard exhaust system

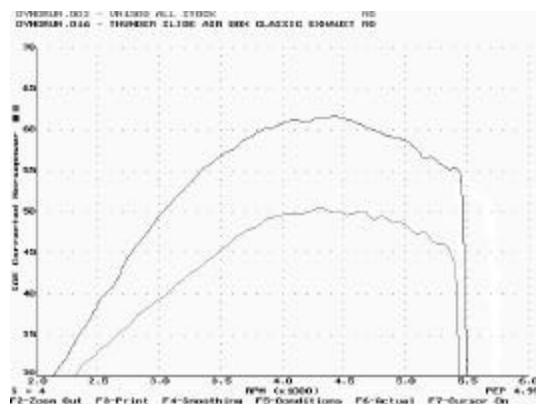

This graph shows a typical gain with a Cobra jet kit.

WARNING

**NO SMOKING!
NO OPEN FLAME!
WHILE INSTALLING
YOUR DYNOJET KIT**

Parts List

1	Main Jet	DJ128
1	Main Jet	DJ130
1	Main Jet	DJ132
1	Main Jet	DJ134
1	Main Jet	DJ136
1	Main Jet	DJ138
1	Main Jet	DJ140
1	Fuel Needle	DNO313
1	E-Clips	DE0001
2	Adjusting Washers	DW0001
1	Plug Drill	DD #5/32
1	Screw	DS0001
1	Slide Drill	DD #50
1	Plug	DJP001

*For racing use only. Not for sale in the State of California.

STAGE ONE INSTRUCTIONS

COBRA
92-4166

1. Remove vacuum slides from carbs. Remove stock needle and spacers, noting order of assembly (Fig.A).
2. Drill the slide lift hole with the DD #50 drill bit provided (Fig. A). **Do not** drill the needle hole.
3. Install the Cobra needle on groove #3 from the top. Use all stock spacers (Fig. A). Install the small Cobra washers above the E-clip. After installing the slide in the carb be sure to check slide movement manually.
4. Remove the stock main jets and replace with the Cobra main jets provided. Use the DJ130 main jet when running the Cobra 2 into1 exhaust. Use the DJ134 main jet when running Cobra drag pipes **WITH** baffles or when running the Cobra 2 into 2 Slash cut mufflers. When running drag pipes **WITHOUT** baffles use the DJ138 main jet. Be sure that the jet you are changing is the main jet.
5. Locate the fuel mixture plug (Fig. B). If you see a screw head at Fig. B then proceed to the adjusting procedure. With the 5/32 drill bit provided carefully drill through the plug. **NOTE:** The mixture screw is directly underneath this plug, be ready to pull back on the drill the instant you break through. Use screw provided to secure and remove this plug. Carefully turn the mixture screw clockwise until lightly seated, then back out 3 turns.
6. Locate the hose shown in Fig. C. The hose is located behind the air box on the left side of the engine. Remove the air filter cover and backing plate. Disconnect the hose and install the Cobra plug (DJP001) in the hose and then reattach the hose (Fig. C).

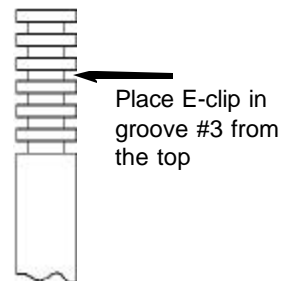

Fig. B

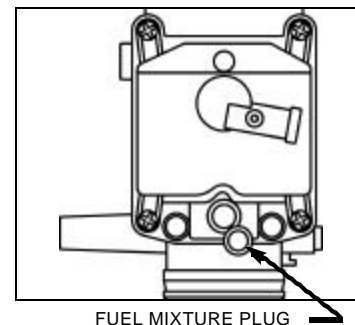

Fig. A

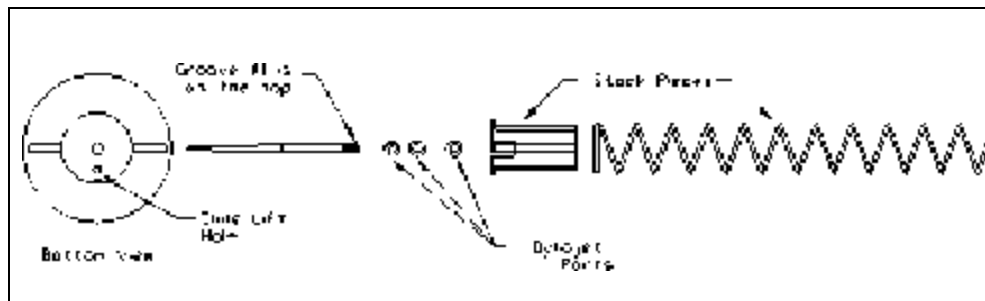

Fig. C

