

Items Supplied >

- 1 – Fi2000 Fuel Injection Module
- 1 – Zip Tie, 3/16" x 6" Long
- 1 – Velcro Strip

Application(s) >

YAMAHA STRYKER 1300 2011-2018

Instruction Manual >

92-1770

Page 1 of 3

Cobra recommends the use of the Closed Loop Module 92-1770CL or 92-1770CL-50 if your motorcycle will continue use of the Oxygen Sensors in your exhaust System. This Fi2000 is intended for motorcycles that will not utilize Oxygen Sensors in the fuel management system.

Read all instructions carefully and completely before installing your new Fi2000CL module.

It is recommended that a qualified mechanic or technician install this product.

Before installing the Fi2000CL it is recommended that the gas tank be low on fuel.

1. Remove the seat. Remove the two 12 mm headed bolts securing the rear of the fuel tank, prop the tank up securely to allow access to the fuel injector connectors.
2. Position the Fi2000R® module in the area under the seat, then feed the Fi2000 injector harness with the four connectors forward under the seat latch bracket, under the fuel tank and along the upper left side frame rail and to the injector area between front and rear engine cylinders, see Figure 1.
3. Locate the front and rear injectors and remove stock female connector from front injector, see Figure 2. On Fi2000 injector harness use the longer of the two connector pairs and install the Fi2000 female connector onto the front injector. Install the corresponding male Fi2000 connector into the stock front female injector connector. Repeat for rear injector using the short pair of Fi2000 connectors. Be sure female connectors seat properly on injectors and the stock connectors are fully pressed together with the Fi2000 male connectors. Tuck these connectors out of the way and lower the fuel tank. Secure Fi2000 harness to left frame rail with 6" zip tie.
4. Remove the right side triangular plastic panel located below the painted right side cover. Push inward on the center of the plastic peg fastener to remove it as the triangular plastic panel is pulled outward, see Figure 3.
5. Locate the stock oxygen sensor connectors, see Figure 4. Unplug this connection to allow the Fi2000R to compensate for fuel properly. The motorcycle will run in its default open loop fuel mode allowing the Fi2000R to take full advantage of its tuning abilities. Reinstall the triangular plastic cover over oxygen sensor connectors, be sure plastic pin is installed correctly.
6. Clean off the top of the fuel pump tank and remove backing from supplied Velcro. Mount the Fi2000 on top of the tank, see Figure 1. Lift up the tool tray / battery cover to access the negative post of the battery. Attach the ground wire from the Fi2000 to the negative post. Reinstall the cover. Before reinstalling the seat, verify Fi2000 harness connections have been made properly.
7. Remove the door from the Fi2000 module to expose the LED's. **NOTE:** The Fi2000 base pot settings come preset from the factory for the Stryker with full exhaust, if a slip-on is used change settings, to those in Figure 6. Verify the wire connections by, (1), turning the ignition on while watching the 3 LED's. They will all light up for a few seconds, and then go off. This is correct. If there are no lights visible, make sure the side stand is up, bike is in neutral, clutch is in and handlebar engine switch is set to run. If there are still no lights visible, re-check that all connectors are fully engaged and the ground wire is connected correctly. (2), after achieving a steady light from all three LED's, start the motorcycle; the green light should now be the only LED on. If all three LED's are still on after start up, verify the injector connectors are correctly attached. Reattach the access door when finished.
NOTE: Make sure the ignition is turned off before changing any connections.

*** For California riders we offer Air Resources Board approved Fi2000 ARB units with Executive Order number D-633-2. All other Fi2000 models are not legal for street use in California. Visit COBRAUSA.COM to choose the correct Fi2000 for your vehicle.**

8. Lower fuel tank and reinstall 12mm headed bolts securely, reinstall seat.

ADVANCED TUNING

The Fi2000R has the ability to efficiently tune the EFI system on your motorcycle for slip-on or full exhaust systems. Your Cobra Fi2000 fuel injection module has been tested and preset for best function and rideability on a motorcycle with aftermarket air cleaner and Cobra full exhaust, settings shown in Figure 5, if your motorcycle is using the Cobra slip-on exhaust, please change the settings to those in Figure 6. Both dyno testing and on-road exhaust gas analysis have been used to develop the best base settings for drivability and power. Not all slip-on mufflers flow exactly the same. Some are made with street baffles, other with race or competition baffles. Full exhaust systems offer even greater variation in construction, features and performance. The Fi2000R has the ability to tune the EFI system on your motorcycle to any of these exhausts by applying a logical and systematic approach to altering the base settings supplied with your Fi2000R. These suggestions should be followed step by step and help you achieve success, should the motorcycle not run optimum with the settings provided.

**** Only attempt adjustments on a fully warmed motor ****

1. Start with the base setting, even if you have a full exhaust system. Adjust and test only *ONE* adjustment pot at a time until you are happy with the result.
2. Start with the left hand or green light pot. This adjustment works either from idle or above idle (varies with bike) to a R.P.M. of about 5000 (also varies with bike) while the bike is driven at a steady throttle or slowly increasing throttle. This is the cruise range and is where the emissions leanness creates issues like choppy on-off throttle application, surging, and backfiring on trailing throttle.
3. Turn this pot back to zero, and make one position increases until you feel the best performance in this range. Do this test a few times to make sure you have it right.
4. The middle or yellow pot is an engine load- triggered fuel adding adjustment. A rapid increase of the throttle at any R.P.M. will add additional fuel and as long as that predetermined load is present, fuel will continue. As engine loads increase in higher gears the acceleration fuel will stay on longer and be more effective. Starting with the base setting, test ride the motorcycle in 4th or 5th gear and perform moderately fast roll-on throttle from a repeating standard R.P.M. or speed. Increase the pot one position at a time and stop as soon as you don't feel any improvement.
5. The right hand or red pot is for the fuel setting required when the engine is maximizing its R.P.M. and power delivery. This pot is similar to the main jet in a carburetor. It will take a combination of a minimum R.P.M. and a predetermined amount of engine load to initiate this fuel. The straightaway on a racetrack or an inertia dyno are the best places to set this pot. Full exhaust systems of high quality construction increase flow characteristics and will increase fuel demands over our base settings. Also, air filters specifically designed for higher than stock airflow can create need for higher fuel setting. Try an additional one-position pot setting at a time.
6. Camshaft changes can alter an engine's volumetric efficiency and create a greater demand on the engine's fuel system than the Fi2000R may have the ability to adjust for.

TROUBLE SHOOTING

If you have any problems refer to: Step 7, in the installation body of these instructions.

Fi2000
INSTALLATION
LOCATION

HARNESS TO
INJECTOR
CONNECTORS

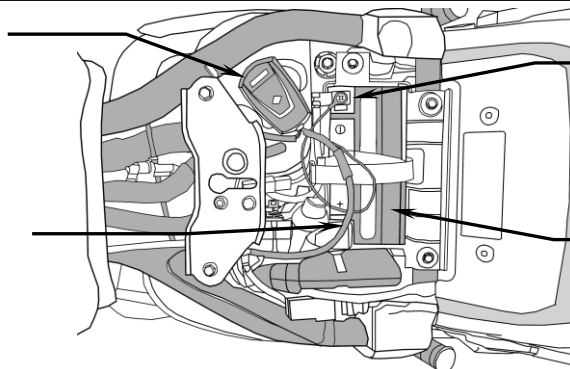

GROUND
WIRE TO
NEGATIVE
BATTERY
TERMINAL

MAIN BATTERY

FIGURE 1

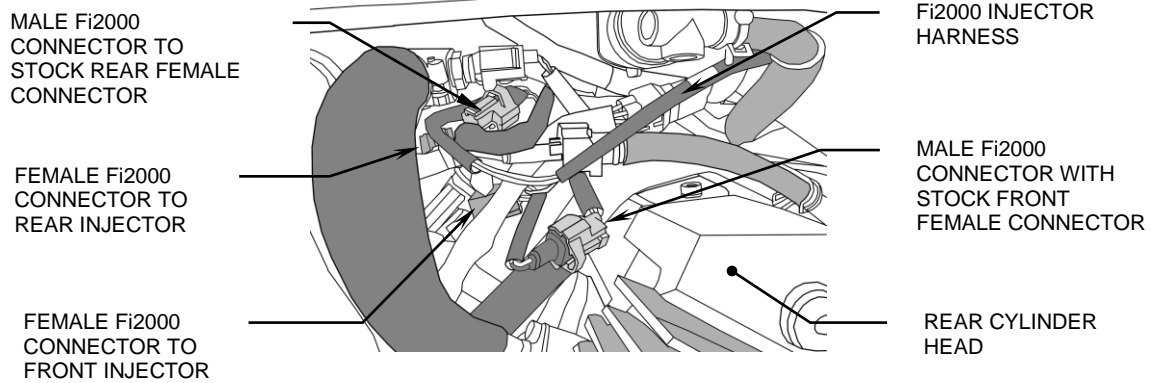

FIGURE 2

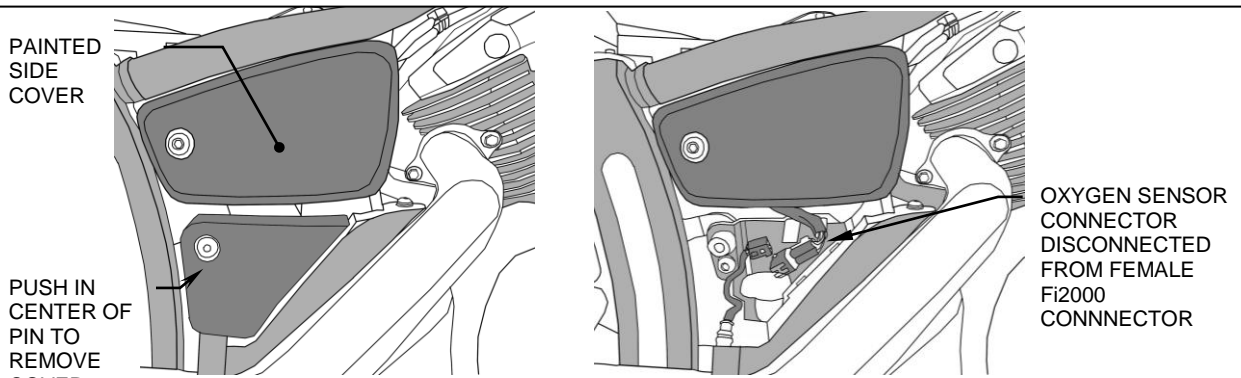

FIGURE 3

FIGURE 4

FULL EXHAUST SYSTEM

Default Pot Settings:

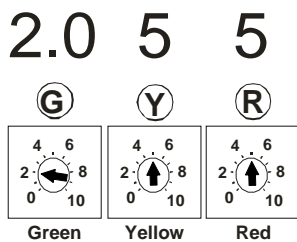

FIGURE 5

SLIP-ON EXHAUST SYSTEM

Default Pot Settings:

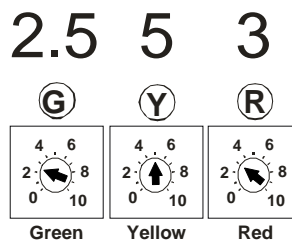

FIGURE 6