

Items Supplied >

- 1 – Powerpro Black Fuel Injection Module
- 2 – 4" Zip Ties Narrow #18 Test
- 1 – Velcro Stripe

Application(s) >

HONDA	
FURY	2010-2016
SABRE	2010-2013
STATELINE	2010-2016
INTERSTATE	2010-2015

Instruction Manual >

92-1633B

Page 1 of 2

Read all instructions carefully and completely before installing your new POWRPRO module.

It is recommended that a qualified mechanic or technician install this product.

Before installing it is recommended that the gas tank be low on fuel.

1. Remove the (4) M6 bolts that hold on the right side air cleaner cover then remove the cover and filter. Remove the air cleaner backing plate by loosening the (4) screws around air inlet (Note: screws will not come out they only loosen) and the (1) M6 hex bolt from the backing plate. See Figure 1.
2. Remove the left side battery box cover and left rear cylinder cover. (Note: no screws hold the covers; simply pull loose from rubber grommets).
3. Route the Fi2000 wire harness from the battery location, following along existing harness under the gas tank, to the right side of motorcycle until reaching the fuel injectors and connectors. See Figures 2 & 3.
4. Note which stock injector connectors belong to front and rear injectors. Disconnect the stock injector connector from the front cylinder and connect the longer female Fi2000 connector to that injector – connect corresponding male connector to stock female connector (removed from front cylinder). See Figure 2.
5. Disconnect the stock injector connector from the rear cylinder and connect the shorter female Fi2000 connector to that injector – connect corresponding male connector to stock female connector (removed from rear cylinder). See Figure 2.
6. Reinstall air cleaner backing plate, air filter, and air cleaner cover in the same manner as it was removed.
7. Attach the ground cable to the NEGATIVE post of the battery. See Figure 3.
8. Verify that the module has power and connections have been made correctly; watch the clear window on the FI housing and turn "ON" the key ignition and set the handlebar run switch to "ON", confirm that the Red LED turns on. On some models the Red light will turn off after 4-5 seconds as the fuel pump cycles off, which is OK. If you do not see a Red light, it may be necessary to wait for the alarm to reset (if applicable) and try again. Also confirm the side stand is up, bike is in neutral, and clutch is in. Start the bike and confirm the LED remains on solid Red. **NOTE:** Make sure ignition is turned off before attempting to change any Fi2000 harness connections if no Red light is seen. For access to the Blue Tooth Tuning App on the module, please download the PowrPro Black App to your smart device, Android 4.3 & later or Apple iOS 5.0 & later operating systems. Once the app is installed, make sure the motorcycle is in neutral and start the engine, use the connect button within the app and the Blue light on the Fi module window will light up during pairing connection and remain solid Blue while paired and connected with respective Android or Apple Device. Once the app has been used and settings saved and disconnected through the app, the Blue light will turn off, and the PowrPro Black will be ready for continued service on the motorcycle. Using the supplied Velcro, mount the Fi2000 module as shown in Figure 4. Zip tie the Fi2000 harness to stock tubes/wire harnesses in the locations shown in Figure 3.
9. Reinstall the battery box cover and rear cylinder cover.

DISCLAIMER: NOT LEGAL FOR SALE OR USE IN CALIFORNIA ON ANY POLLUTION CONTROLLED MOTOR VEHICLES.

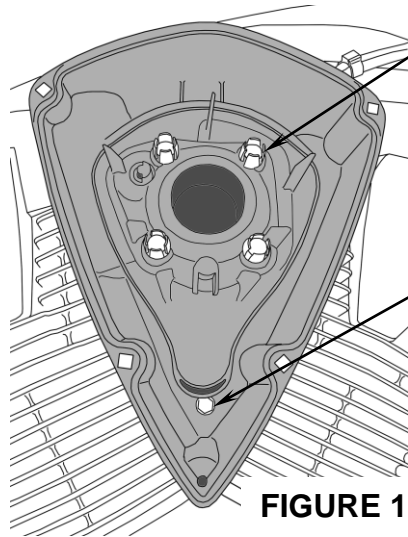

FIGURE 1

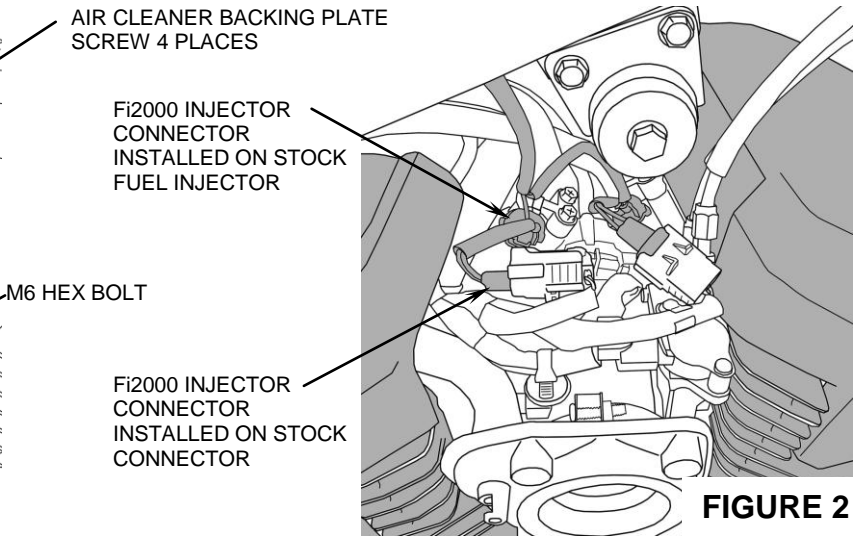

FIGURE 2

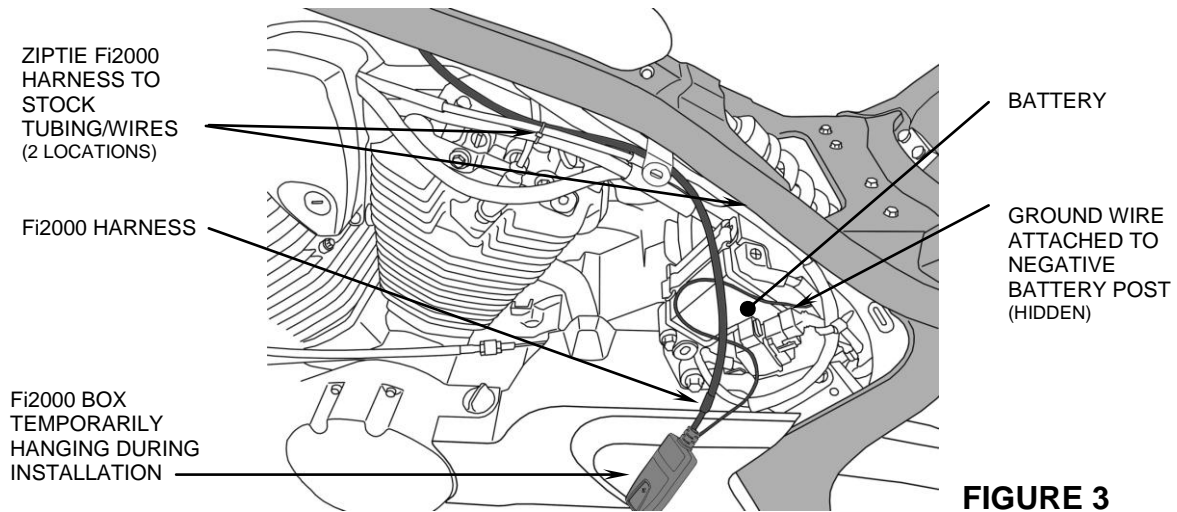

FIGURE 3

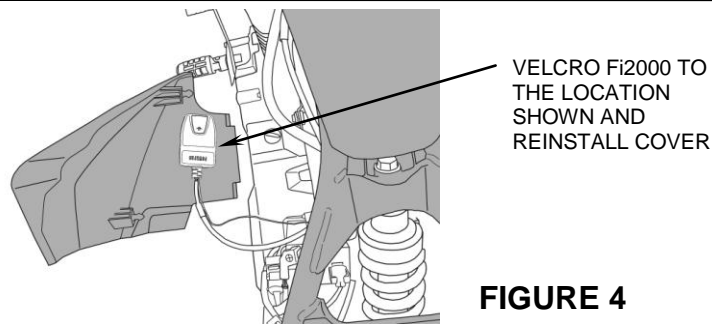

FIGURE 4

DISCLAIMER: NOT LEGAL FOR SALE OR USE IN CALIFORNIA ON ANY POLLUTION CONTROLLED MOTOR VEHICLES.