

Items Supplied >

- 1 – FRONT MUFFLER ASSEMBLY
- 1 – REAR MUFFLER ASSEMBLY

Application >

HARLEY:	
FATBOY	00-06
SOFTAIL DEUCE	00-06

Instruction Manual >

6050

Page 1 of 1

Read all instructions carefully and completely before installing your new slip-on mufflers

1. Remove the stock muffler mounting bolts and save.
2. Loosen the stock muffler clamps then pull both mufflers (in unison) from the head pipes. Save the stock clamps because they will be reused.
3. Remove the gasket from the stock muffler crossover slip and install it into the new crossover slip on the rear muffler. If needed, a replacement gasket can be purchased through your dealer (HD Part #65830-03).
4. Position the stock clamps with hex head as shown in **Figure 1** and slide them onto the slip-on mufflers.
5. **NOTE: THE MUFFLER WITH THE COBRA LOGO WILL ALWAYS BE THE REAR MUFFLER.** Connect the crossover slips together and slide both mufflers onto the head pipes in unison (reverse the order of removal) until the mounting holes align.
6. Fasten the mufflers using the stock mounting bolts in the same manner as stock but **do not tighten**. Verify that the gap, where the mufflers meet the stock heat shields, is similar to the gap the stock mufflers allotted.
7. Check all clearances and alignments then tighten the clamps. (NOTE: The muffler clamps should be flush with the end of the muffler when tightened. See **Figure 2**. If the muffler clamps are slid forward past the slots on the slip collar the clamps will not tighten the mufflers properly. Also, make sure the clamp spacer is not over the slots. The slots need to be covered by the clamp band so that it seals the slots properly. Rotate the clamp if necessary).
8. Tighten the mounting bolts to factory specifications.
9. **IMPORTANT: Before starting your engine remove all fingerprints from chrome with a quality wax or chrome polish. Failure to do so can cause chrome discoloration. Due to fluctuations in fuel delivery settings, timing, etc., Cobra Engineering does not warrant against chrome discoloration.**

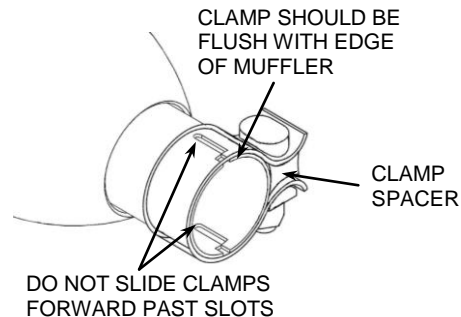
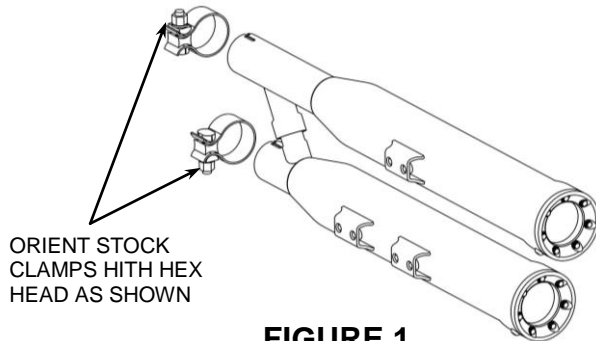

POSITION OF MUFFLERS AND MOUNTING BRACKETS SHOWN ABOVE MAY VARY FROM ACTUAL APPLICATION

REPLACEMENT E-GLASS PACKING AND OPTIONAL 1 1/4" QUIET CORES MAY BE PURCHASED THROUGH YOUR DEALER OR ONLINE AT WWW.COBRUSA.COM

DISCLAIMER: NOT LEGAL FOR SALE OR USE IN CALIFORNIA ON ANY POLLUTION CONTROLLED MOTOR VEHICLE. THE SALE, USE, OR INSTALLATION OF THIS PRODUCT MAY ALSO BE ILLEGAL NATIONWIDE UNDER THE FEDERAL CLEAN AIR ACT (42 U.S.C. § 7522(A)(3)).