

Items Supplied >

- 1 – FRONT EXHAUST ASSEMBLY
- 1 – REAR EXHAUST ASSEMBLY
- 5 – HOSE CLAMPS (Speedster short pipes only)
- 6 – HOSE CLAMPS (Speedster long pipes only)
- 2 – FLANGE, EXHAUST
- 2 – BOLT, HEX 5/16-18 x .63
- 2 – SCREW, BUTTON ¼-20 x .38
- 2 – BILLET MUFFLER TIPS

Application(s) >

KAWASAKI VN2000

04-10

Instruction Manual >

4723 / 4923

Page 1 of 2

PRIOR TO INSTALLATION, MAKE SURE YOUR STOCK HEADPIPE GASKETS ARE IN GOOD SHAPE. IF YOU HAVE ANY DOUBTS AS TO THEIR CONDITION, REPLACE THEM.

Read all instructions carefully and completely before installing your new exhaust system

1. Loosen the right floorboard assembly and slide it away from the frame.
2. Remove the stock exhaust system making sure to unplug the oxygen sensor if equipped. **NOTE: Some models equipped with an oxygen sensor will need to install Cobra P/N 92-1101 to prevent premature illumination of the warning light.**
3. Remove the stock exhaust-mounting bracket. **NOTE: The bracket brake line guide must be cut and spread apart so you can remove the brake line from the bracket.** Refer to Figure 1. **DO NOT REMOVE THE STOCK BRAKE LINE.**
4. Install the new exhaust mount bracket using the stock hardware removed in step 2. **DO NOT TIGHTEN** at this time.
5. Remove the Cobra headpipes from the box. Slide one exhaust flange onto each headpipe. Important: Each flange is marked up, the up mark should be on top with the short hole located forward, see Figure 2.
6. Install the front and rear headpipes on the motorcycle but do not tighten. Make sure the pipes are parallel with each other.
7. Remove the muffler assembly from the box and slide one supplied clamp #27-61MSC onto each muffler tube. Refer to Figure 3 for proper alignment.
8. Slide the muffler assembly onto the head pipes by tapping on the head pipes with your hand as you push the mufflers forward making sure the assembly slides as far forward as possible. Secure the muffler assembly to the mounting bracket using the supplied 5/16-18 bolts but **do not tighten**.
9. Make sure the muffler assembly is parallel to the ground (this is critical) then tighten the following in order, muffler bracket to the frame, muffler assembly to the muffler bracket, head pipe flanges to the motor (slowly tighten opposing nut) and muffler clamps. (NOTE: If the muffler clamps are slid to far up the muffler or past the three slots, the clamps will not tighten.)
10. Unscrew the remaining hose clamps and feed the tail end of the clamp through the clips on the inside of the heat shields. The screw end of the hose clamp should be accessible for tightening but not visible when the heat shields are mounted to the pipes, see Figure 3
11. To install the front heatshield, first slide the rear portion of the heatshield over the muffler, continue to slowly slide it forward pushing the front of the shield gently into place between the frame and motor (Hint: Spread the hose clamps apart slightly to make it easier to slide them over the muffler assembly and head pipes). Make sure the muffler clamps don't interfere with the heatshields and are aligned as shown in Figure 3. Snug the heatshield clamps but **DO NOT TIGHTEN**.

*** Cobra® recommends you always wear a helmet while riding. Please never operate your motorcycle while under the influence of alcohol and/or drugs. Enjoy the new look of your motorcycle and please ride safely.**

12. Install the rear heatshield the same way as the front heatshield.
13. Make sure the front and rear heatshields are even on the back with each other. Install one billet tip on each heatshield. Fasten the tips with the supplied ¼-20 screws making sure they snug up against the heatshield leaving no gap between the tip and heatshield when tighten. **If it is difficult to slide the tips into the heatshields loosen the clamps on the heatshield, failure to do this may cause damage to the chrome tips.**
14. Tighten the clamps on the heatshields.
15. Reinstall the floorboard assembly and hardware removed in step 1 and tighten to factory specifications. Make sure all the hardware (brackets, headpipes, heatshields, mufflers and baffles) has been tightened appropriately and cleaned before starting your motorcycle.

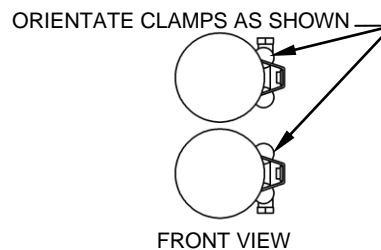
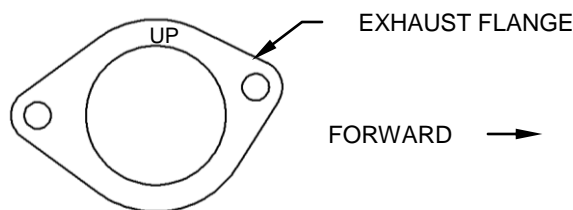
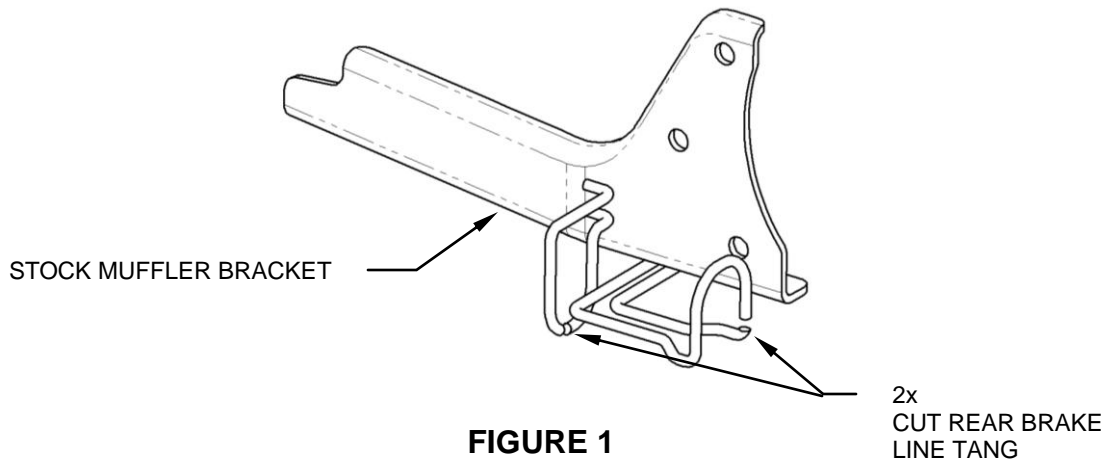

NOTE: If your motorcycle came equipped with an O2 sensor in the stock exhaust will need to install a Cobra O2 sensor removal kit part number 92-1101.

IMPORTANT: It is recommended that you install a Cobra Fi2000® Digital Fuel Processor with your Cobra exhaust system. Cobra is not responsible for the performance of any other fuel management system used with Cobra exhaust systems. **VN2000 Fi2000R, Part #: 92-1964**

Before starting your engine remove all fingerprints from chrome with a quality wax or chrome polish. Failure to do so can cause discoloration. Due to fluctuations in fuel injection settings, timing, etc., Cobra Engineering does not warrant against chrome discoloration.

California does not allow the use of aftermarket exhaust systems that remove original equipment catalysts, (except for racing use only) unless the Air Resources Board has issued an Executive Order for that system.