

Items Supplied >

- 1 – Exhaust Mount
- 1 – Front Head Pipe
- 1 – Rear Head Pipe
- 1 – Front Heat Shield
- 1 – Rear Heat Shield
- 1 – Muffler Set
- 1 – Regulator Bracket
- 1 – Black Round Spacer
- 1 – Hardware Kit

Application >

KAWASAKI VULCAN 1500D/E/N/P 96-03
KAWASAKI VULCAN1600B 04-08
SUZUKI MARAUDER 1600 2004

Instruction Manual >

4569SC/4869

Page 1 of 2

PRIOR TO INSTALLATION, MAKE SURE YOUR STOCK HEADPIPE GASKETS ARE IN GOOD SHAPE. IF YOU HAVE ANY DOUBTS AS TO THEIR CONDITION, REPLACE THEM.

1. Remove stock exhaust system.
2. Remove mufflers from box and set them on a flat surface with brackets pointing up and the small ends of the mufflers are to your right. Locate the two slider brackets in the hardware kit. Place one slider bracket inside each muffler bracket with the flat side of the bracket pointing up.
3. Remove the exhaust mounting bracket from the box and place on top of the muffler brackets with the small bracket to your right pointing upward and the larger bracket to your left pointing downward. (See Figure 1). Install the four 5/16" bolts through the mounting bracket and into the slider bracket but **DO NOT TIGHTEN**.
4. Slide one supplied clamp #27-61MSC onto each muffler and position as shown in Figure 2.
5. Install the rear head pipe using the stock hardware but **DO NOT TIGHTEN**.
6. Slide the top muffler over the rear head pipe and align holes in the mounting bracket with the holes in the frame bracket. NOTE: Be sure the mounting bracket is mounted behind the frame bracket. Using stock hardware, secure the mounting bracket to the frame bracket. **Note: On the Mean Streak and Marauder models place the supplied black spacer between back of passenger foot peg mount and exhaust pipe bracket, refer to fig. 3, using all the stock hardware except for the small washer, which is not used.**
7. Slip the front head pipe into the lower muffler and pivot head pipe into front exhaust port. Using stock hardware, snug head pipe into place. NOTE: It may be necessary to loosen or remove your right floorboard assembly to allow you to rotate the head pipe into place. Make sure mufflers and head pipes are parallel.
8. Unscrew the four remaining hose clamps and feed the tail end of the clamp through the clips on the inside of the heat shields. The screw end of the hose clamp should be accessible for tightening but not visible when the heat shields are mounted to the pipes. Place the heat shields onto the head pipes but leave loose.
9. Adjust the mufflers so that they are in proper alignment with the heat shields as shown in Figure 2. NOTE: On Part #4566SC, the heat shield should cover the weld. Rotate the muffler clamps so they don't interfere with the heat shield fitment but are still accessible to tighten. (NOTE: If the clamps are slid to far up on the muffler or past the slots, the clamps will not tighten.)
10. Tighten the head pipes making sure to tighten evenly.
11. Tighten remaining hardware in the following order; muffler bolts, muffler clamps, mounting bracket and then heat shields.
12. Remove the regulator cover, regulator and regulator bracket from the lower left side of the bike.
13. Install the regulator onto the Cobra black regulator relocation bracket using the stock bolts and two (2) 6mm nylock nuts supplied.
14. Install the bracket with the regulator between the muffler mounts under the swing arm using the stock bolts and supplied M10 nut's & lock washer's.

*** Cobra recommends you always wear a helmet while riding. Please never operate your motorcycle while under the influence of alcohol and/or drugs. Enjoy the new look of your motorcycle and please ride safely.**

15. Make sure all the hardware (brackets, headpipes, heatshields, mufflers and baffles) has been tightened appropriately before starting your motorcycle.

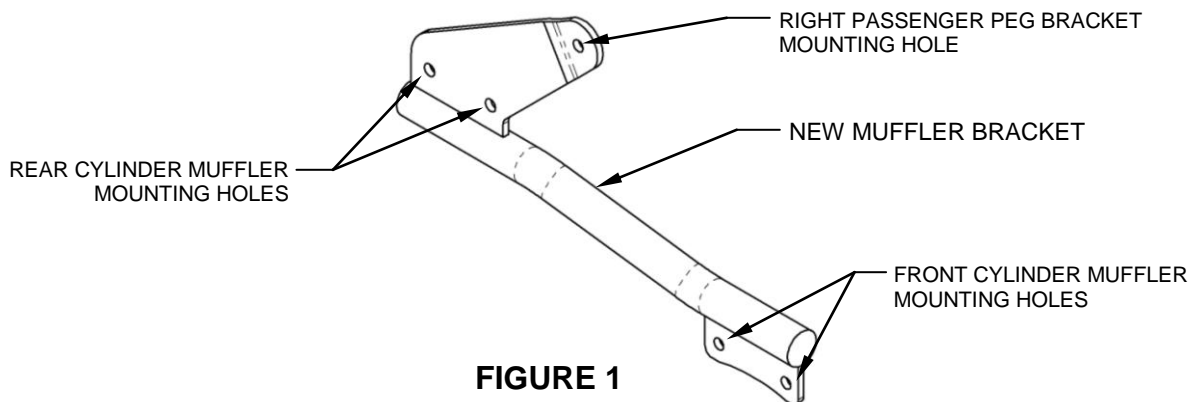

FIGURE 1

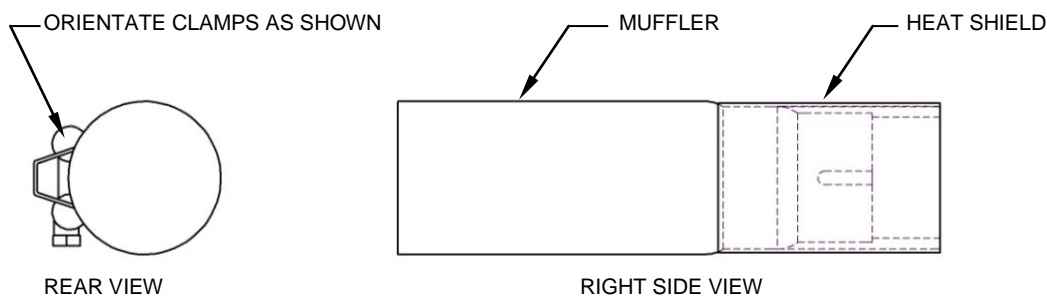

FIGURE 2

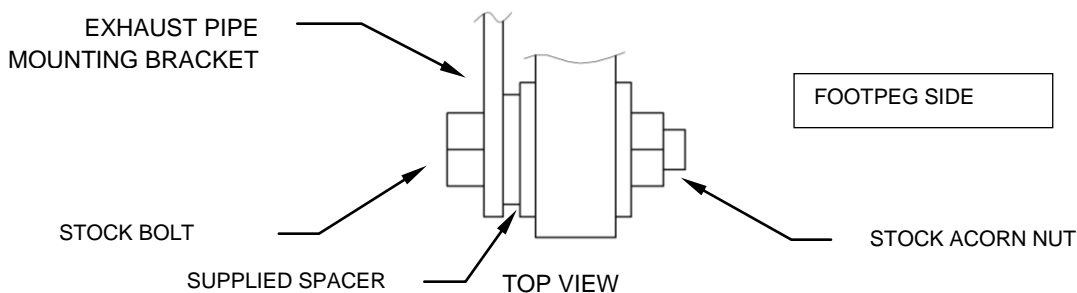

FIGURE 3
(MEAN STREAK and MARAUDER ONLY)

IMPORTANT: Carbureted models it is recommended that you re-jet your bike with a Cobra Jet Kit, part # 92-4166.

Fuel It is recommended that you install a Cobra Fi2000® Digital Fuel Processor with your Cobra exhaust system.
Injected Models Cobra is not responsible for the performance of any other fuel management system used with Cobra exhaust systems. **VN1500N Classic Fi2000 (part# 92-0940), VN1500P Mean Streak (part#92-0960), VN1600B Mean Streak/ VZ1600 Marauder (part#92-0962)**

Before starting your engine remove all fingerprints from chrome with a quality wax or chrome polish. Failure to do so can cause discoloration. Due to fluctuations in carburetor settings, timing, etc., Cobra Engineering does not warrant against chrome discoloration.

California does not allow the use of aftermarket exhaust systems that remove original equipment catalysts, (except for racing use only) unless the Air Resources Board has issued an Executive Order for that system.