

Items Supplied >

- 1 – FRONT MUFFLER BODY
- 1 – REAR MUFFLER BODY
- 1 – HOSE CLAMP, 27-56MSS (SMALL)
- 1 – HOSE CLAMP, 27-54MSS (LARGE)
- 1 – FRONT HEATSHIELD, 1-1/2"
- 1 – REAR HEATSHIELD, 1-3/8"
- 2 – M8 x 12mm HEX FLANGE BOLT

Application(s) >

HONDA FURY	2010-2014
SABRE	2010-2014
STATELINE	2010-2014
INTERSTATE	2010-2014

Instruction Manual >

1133

Page 1 of 2

Read all instructions carefully and completely before installing your new slip-on mufflers.

1. Loosen the stock muffler clamps on both rear and front mufflers.
2. Remove the (2) M8 bolts, washers and nuts securing the stock mufflers to exhaust mount bracket. Save all hardware for later use. Remove mufflers by pulling rearward.
3. Remove new Cobra slip-on mufflers from box. Identify the front muffler body (see Figure 1) and install the (larger) 27-56MSS clamp and supplied 1-1/2" heatshield (P/N 5421) onto the muffler inlet and orientate hex head as shown in Figure 1. (**NOTE:** *The two different clamps and heatshields appear similar, but it is CRITICAL that these components are matched correctly as per these instructions. Refer to Figure 1 for clarification.*)
4. Slide the front muffler onto the front cylinder headpipe. Slide muffler forward until muffler inlet is fully engaged and the lower muffler bracket aligns with the exhaust mount bracket. See Figure 1.
 - a. Insert the longer stock M8 bolt through the front hole of the muffler bracket, exhaust mount, large washer and secure with a stock nut on backside. **DO NOT TIGHTEN!**
 - b. Insert the shorter stock M8 bolt through the rear hole of the muffler bracket, exhaust mount, small washer and secure with a stock nut on backside. **DO NOT TIGHTEN!**
5. Take rear muffler body (see Figure 1) and install the (smaller) 27-54MSS clamp and supplied 1-3/8" heatshield (P/N 5422) onto the muffler inlet and orientate hex head as shown in Figure 1.
6. Slide the rear muffler onto the rear cylinder headpipe. Slide muffler forward until muffler inlet is fully engaged. Align the rear muffler's mounting brackets with the upper brackets on the front muffler and insert the (2) supplied M8 x 12mm hex flange bolts but **DO NOT TIGHTEN!**
7. Align the mufflers so they are parallel with the headpipes and with each other. NOTE: to align properly you may have to slightly loosen front and rear headpipe flange nuts, align and retighten to appropriate torque.
8. Align the rear muffler 1-3/8" heatshield so the top upper edge aligns with the main stock heatshield, See Figure 2. Align the front muffler 1-1/2" heatshield so the cut away section is not visible, and it is aligned fore to aft with rear 1-3/8" heatshield, See Figure 3.
9. Fully tighten the two clamps around the muffler's inlets. NOTE: (If the muffler clamps are slid to far back on the muffler or past the slots, the clamps will not tighten properly possibly allowing the mufflers to leak).
10. Fully tighten the hardware securing the front muffler to the exhaust mount bracket. Finally tighten the (2) M8 bolts securing the rear muffler to the front muffler.

* Exhaust tips may be orientated in (3) different positions for different visual effects by removing tip retaining bolts. Rotate tips clockwise or counterclockwise and align holes in tips with holes in muffler bodies. Re-install tip bolts and tighten.

* **Cobra® recommends you always wear a helmet while riding. Please never operate your motorcycle while under the influence of alcohol and/or drugs. Enjoy the new look of your motorcycle and please ride safely.**

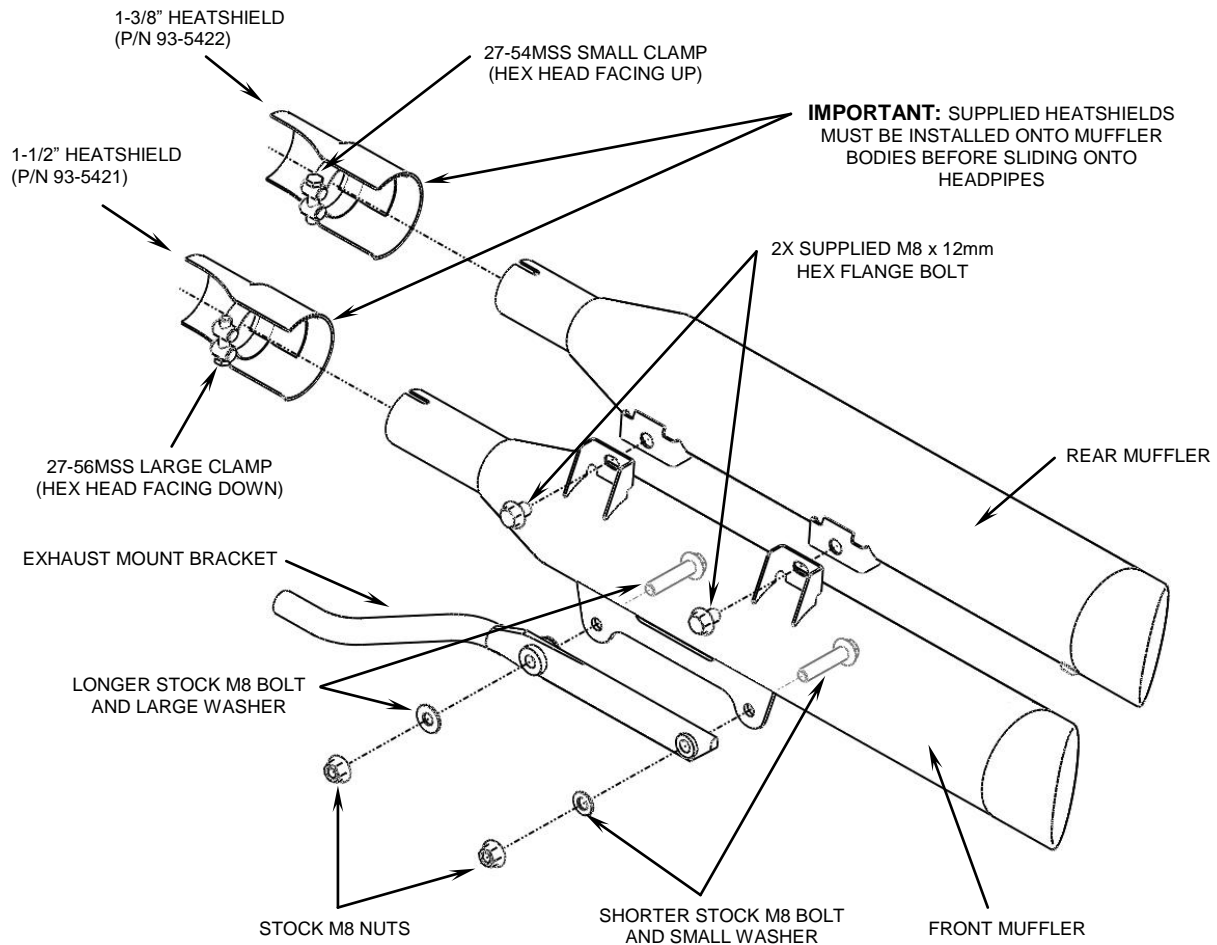

FIGURE 1

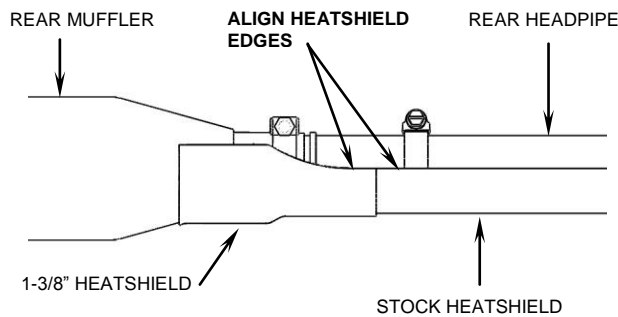

FIGURE 2
(TOP VIEW)

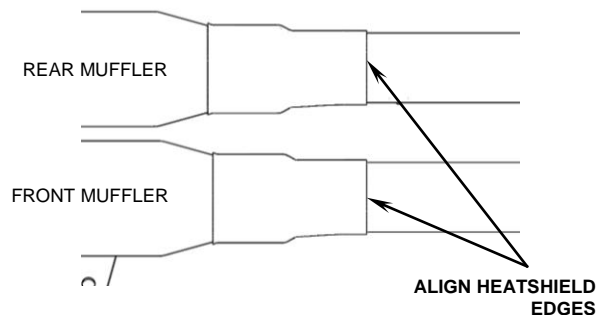

FIGURE 3

California does not allow the use of aftermarket exhaust systems that remove original equipment catalyts, (except for racing use only) unless the Air Resources Board has issued an Executive Order for that system.