

Items Supplied >

- 1 – FREEWAY BAR
- 1 – HORN RELOCATION BRACKET
- 2 – BILLET CLAMPS
- 2 – SPACERS
- 4 – BOLT, BUTTONHEAD M8 X 20mm

Application(s) >

KAWASAKI VN1700 CLASSIC/LT 09-13

Note: Freeway bar will not work with Kawasaki brand Windshield Lowers (P/N 99994-0160)

Instruction Manual >

01-2465

Page 1 of 1

Read all instructions carefully before installing your new Cobra® product!

1. Disconnect the horn's wires from the horn located on front frame neck. Remove the horn and secure it to the supplied horn relocation bracket using the stock bolt. Note the horn's locking tab location. See Figure 1.
2. On the backside of the radiator remove the upper left bolt that secures the radiator fan assembly. Position the horn relocation bracket on the surface where the bolt was removed from, then reinsert and tighten the stock bolt. See Figure 1. Reroute the horn wire harness over the top of the radiator and down the left frame tube and reconnect wires to the horn.
3. Remove the (4) M10 bolts from the right and left floorboard assemblies and save.
4. Slide the new Cobra freeway bar between frame and front fender with the lower mount brackets facing to the rear between the frame and floorboard mounts. On the right side insert one of the stock M10 bolt through the floorboard mount **front** hole, freeway bar mount and into the frame. Then insert one stock M10 bolt through the floorboard mount **rear** hole, supplied spacer and into the frame. **DO NOT FULLY TIGHTEN BOLTS.** Repeat step for left side.
5. To mount the upper portion of the freeway bar place the two billet clamps over the two front frame tubes, just above the radiator, with the threaded holes facing outward. Align the clamps so that you can insert the supplied M8 x 20mm bolts through the upper freeway bar bracket and into the billet clamps. See Figure 2. **DO NOT FULLY TIGHTEN BOLTS.**
6. Torque the (4) M10 bolts on the lower freeway bar / floorboard mounts to their appropriate factory torque values. Then fully tighten the front M8 bolts on the upper clamps, followed by the rear M8 bolts making sure the clamps are seated tight against the frame tubes and do not rotate. Test horn to verify functionality before riding.

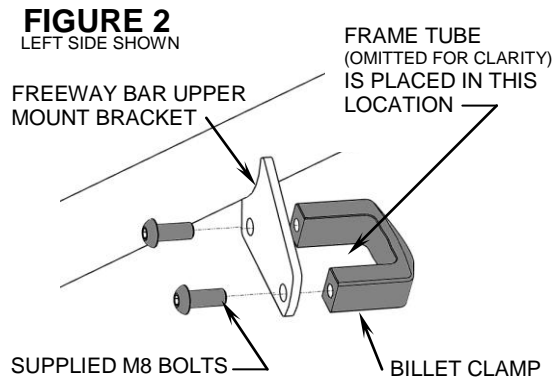
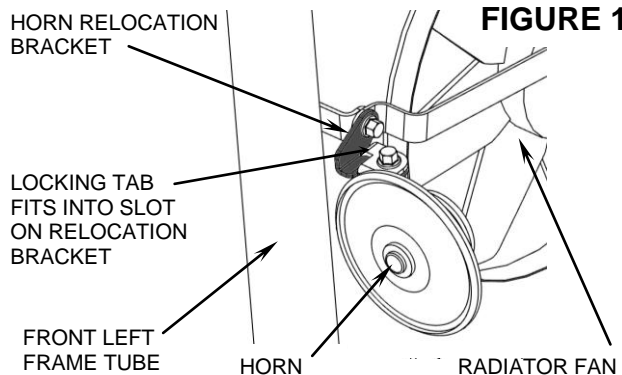

* Cobra® recommends you always wear a helmet while riding. Please never operate your motorcycle while under the influence of alcohol and/or drugs. Enjoy the new look of your motorcycle and please ride safely.