

## Items Supplied >

- 1 - FREEWAY BARS
- 2 - BOLT, M6 x 20mm HEX FLANGE
- 2 - BOLT, M10 X 90mm HEX FLANGE
- 2 - BOLT, M10 X 80mm HEX FLANGE

## Application >

YAMAHA STRYKER

2011-2014

## Instruction Manual >

01-1270

Page 1 of 1

**Before installing your new Cobra® freeway bar, read all instructions carefully.**

1. Remove and discard the bolts securing left and right rider footpeg mounts; carefully let mounts hang by the wires, hoses etc.
2. Remove and discard the (2) M6 buttonhead bolts above the radiator.
3. Position the freeway bar into place and align the upper mounts with the open holes exposed in Step 2 and start threading the (2) supplied M6x 20mm hex flange bolts through the upper mounts, frame and into the nut plate on the backside, but **DO NOT FULLY TIGHTEN BOLTS**. See Figure 1.
4. Align lower mounts with the mounting holes on the frame. Position the left footpeg mount over the freeway bar's lower mount and secure with the (2) supplied M10 x 80mm hex bolts. Repeat on right side using the M10 x 90mm hex bolts. **DO NOT FULLY TIGHTEN BOLTS**. See Figure 1.
5. Align and level the freeway bar then fully tighten the (2) M6 x 20mm hex flange bolts. Tighten the (4) M10 bolts securing the footpeg mounts to factory specifications.
6. Before riding, make sure that the freeway bar is fixed and rigid.

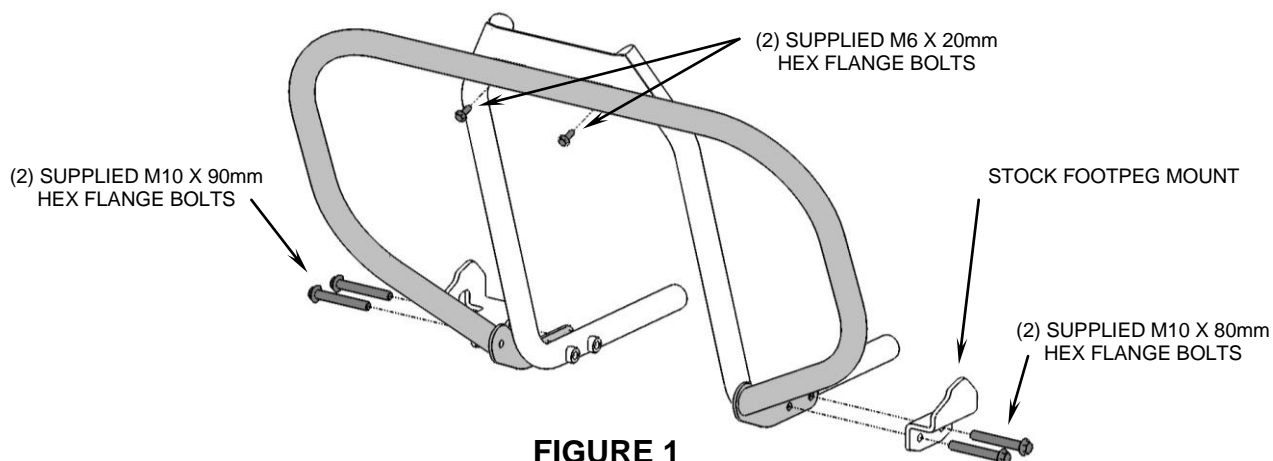

**FIGURE 1**

(ONLY COMPONENTS RELATED TO INSTALLATION ARE SHOWN)  
(STOCK FOOTPEG MOUNTS HAVE BEEN SIMPLIFIED FOR DIAGRAM CLARITY)

**\*Cobra Freeway Bars add style to your motorcycle. They are not designed to withstand a serious impact and may not protect you and/or your motorcycle in the event of a crash.**

**\* Cobra® recommends you always wear a helmet while riding. Please never operate your motorcycle while under the influence of alcohol and/or drugs. Enjoy the new look of your motorcycle and please ride safely.**