

## Items Supplied >

- 1 - Sissy Bar w/Pad
- 2 - Side Brackets
- 4 - Spacers
- 2 - Short M8 x 40 mm Button Head Bolts
- 2 - Long M8 x 45 mm Button Head Bolts
- 4 - 8mm x 20mm Button Head Bolts

## Application(s) >

Yamaha V-Star 1300 07-14

## Instruction Manual >

02-7745 / 02-8745

Page 1 of 1

**Read all instructions carefully before installing your new Cobra product!**

**Your sissy bar will install in just a few minutes using common tools. Read all instructions carefully and completely before installing your new sissy bar.**

1. Remove and discard the (2) M8 bolts from the left side fender rail. Remove the chrome fender rail cover. Install left sissy bar mounting bracket (*part # should face inward*) by inserting the supplied M8 x 45 mm bolt through the front hole of the stock chrome cover, sissy bar mount bracket, supplied spacer, and into the front fender rail. Insert the supplied M8 x 40 mm bolt through the rear hole of the stock chrome cover, sissy bar mount bracket, supplied spacer and into the fender rail (**Do Not Tighten**). Repeat procedure on right side.
2. Install the sissy bar between the brackets using the four (4) supplied 8mm x 20mm button head bolts.
3. Align sissy bar and tighten all hardware. Torque all bolts to their appropriate values.

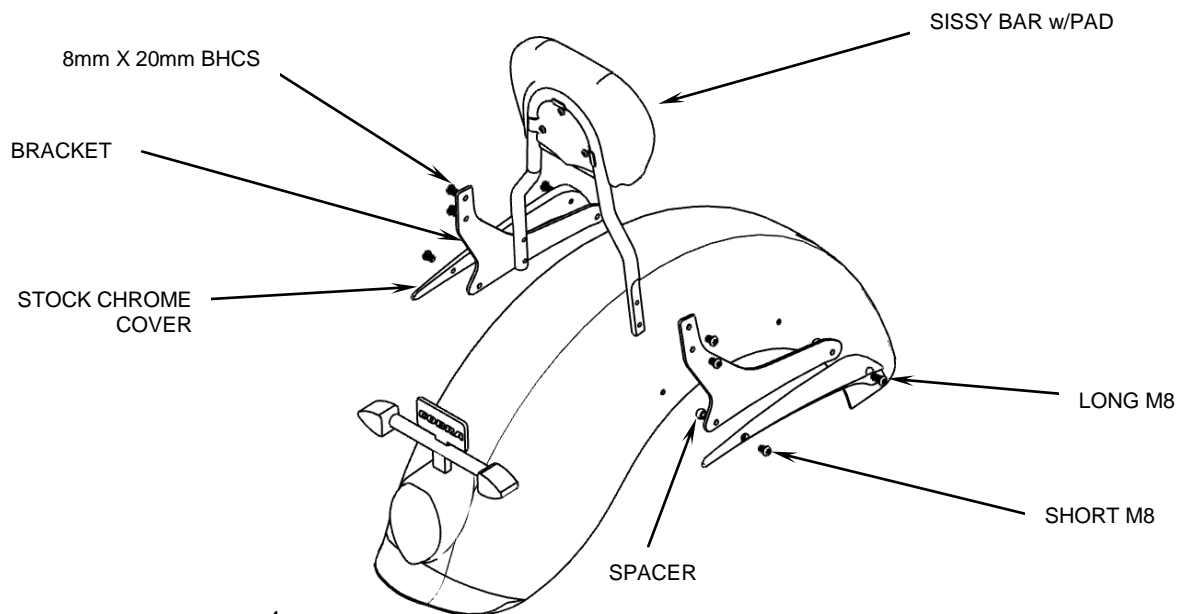

**\* Cobra® recommends you always wear a helmet while riding. Please never operate your motorcycle while under the influence of alcohol and/or drugs. Enjoy the new look of your motorcycle and please ride safely.**