

Items Supplied >

- 1 – CHROMED TRUNK RACK
- 4 – SCREWS, BUTTONHEAD M6 X 16 mm
- 4 – WASHER, RUBBER .650" OD X .250" ID
- 4 – WASHER, STEEL 1.25" OD X .250" ID
- 4 – NUT, NYLOCK M6

Application(s) >

KAWASAKI VOYAGER 2010-2019

Instruction Manual >

02-4469

Page 1 of 2

Read all instructions carefully before installing your new Cobra product!

1. Place masking tape on trunk to prepare for hole drilling to mount the luggage rack, review Figure 1 for tape locations. 2.0 inch wide blue tape should be used.

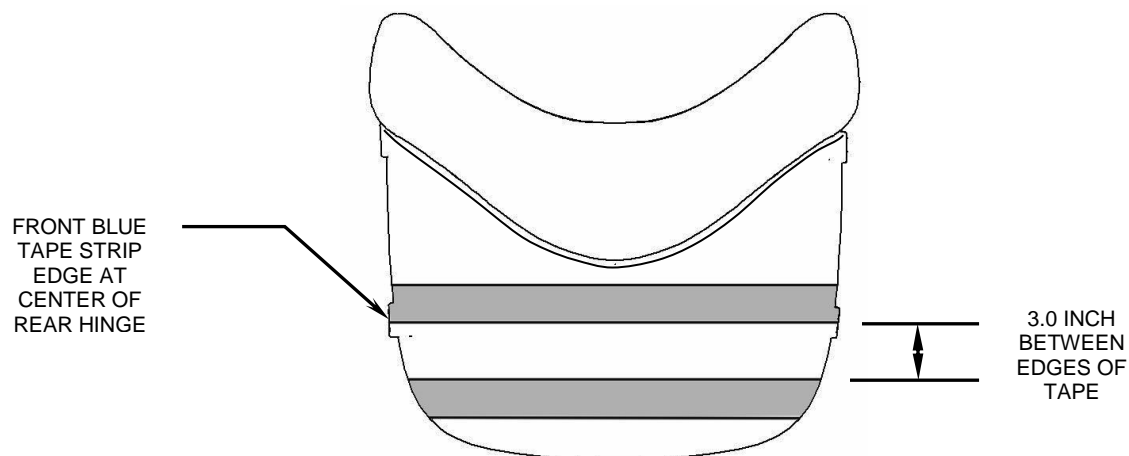

FIGURE 1

2. Assistance may be necessary to hold trunk rack in proper position for marking holes for drilling locations. A piece of tape may be wrapped around the front edge of the rack in the middle and then attached to the seat to ease in positioning the rack.
3. Place the trunk rack on the tape areas, and center the rack from side to side visually. At the front mounting tab locations, measure from the front edge of the trunk to the center of the hole in the front mounting tab locations. This measurement should be approximately 3.50 inches on both sides, see Figure 2. For reference the rack should be approximately 5.25 inches from center of the trunk to center of each front leg hole.
4. Mark the center of the front mounting holes on the masking tape using a pencil or fine point marker and remove the luggage rack so the front holes may be drilled.

*** Cobra recommends you always wear a helmet while riding. Please never operate your motorcycle while under the influence of alcohol and/or drugs. Enjoy the new look of your motorcycle and please ride safely.**

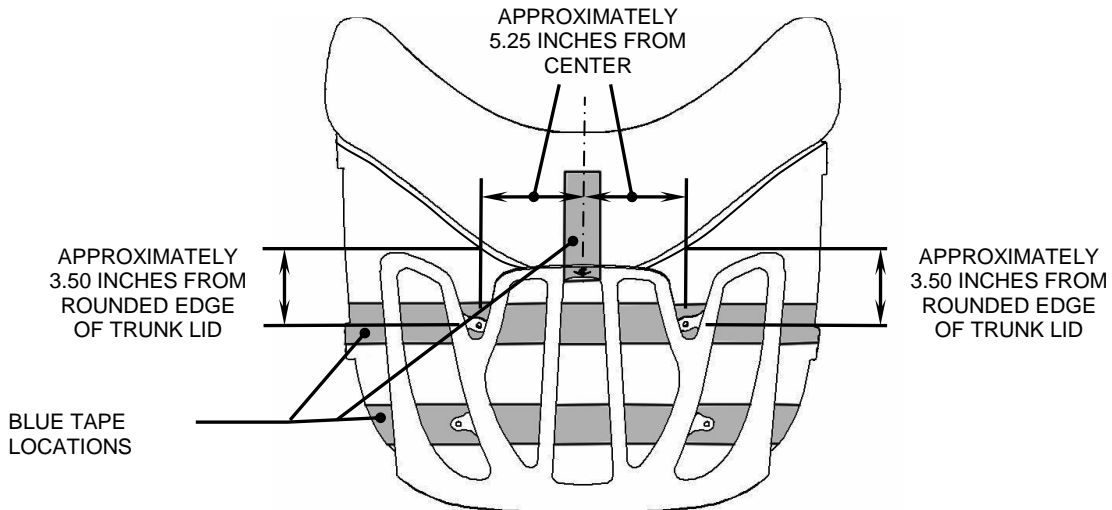

FIGURE 2

5. A 1/4 inch drill bit needs to be used to drill the front mounting holes, we recommend using a smaller drill bit such as 1/16th inch to pilot drill the hole through the plastic. Once both pilot holes have been drilled, use the 1/4 inch drill bit to reach the final diameter.
6. Place a rubber washer between the front feet of the rack and the trunk, leave the masking tape in place for now. Insert a M6 x 16mm buttonhead screw through each front mount, rubber washer, trunk lid and large washer from the inside. Align rack side to side and fore / aft and snug the nylock nuts.
7. Now with the front mounts firmly secured, mark the center of the rear trunk mounts on the tape using a pencil or fine point marker.
8. Remove the rack and repeat the drilling process for the rear holes using a 1/16th inch drill bit to pilot drill the holes and then a 1/4 inch drill bit to reach the final size.
9. Once all holes have been drilled, remove all of the masking tape. Place a M6 x 16 mm screw through the top of each rack leg hole, and place a rubber washer under each leg of the trunk rack. Position the rack on top of the trunk lid and install the rack in drilled holes.
10. With the help of an assistant place a steel washer, and nylock nut on each protruding screw on the inside of the trunk lid. Again align the rack side to side and fore / aft and tighten nuts firmly. See Figure 3.

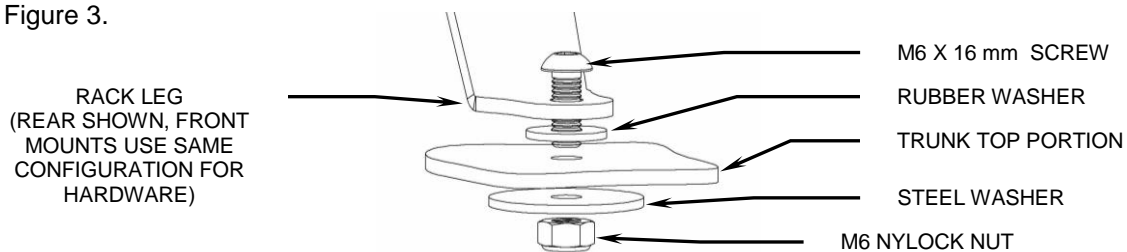

FIGURE 3

ATTENTION: WHEN OPENING THE TRUNK LID, BE SURE TO SET IT AGAINST THE STOP FULLY BY HAND, **DO NOT** LET IT SLAM OPEN, AS DAMAGE MAY OCCUR IF ALLOWED TO SLAM OPEN.