

Items Supplied >

- 1 – FREEWAY BAR
- 2 – BILLET CLAMPS
- 2 – BOLT, FLANGED HEX M10-1.25 X 80 mm
- 2 – BOLT, BUTTONHEAD M8 X 16mm

Application(s) >

YAMAHA V-STAR 950/TOURER 09-18

Instruction Manual >

01-1225

Page 1 of 1

Read all instructions carefully before installing your new Cobra® product!

1. Remove the (2) M10 bolts from the right floorboard mount and save. Remove the (2) M10 bolts from the left side floorboard mount and discard.
2. Slide the new Cobra freeway bar between frame and front fender with the lower mount brackets facing to the rear between the frame and floorboard mounts. On the **right** side insert (2) stock M10 bolts through floorboard mount, then freeway bar mount and into frame. On the **left** side insert supplied M10-1.25 x 80mm bolt through floorboard mount, freeway bar mount, and into frame. **DO NOT FULLY TIGHTEN BOLTS.**
3. To mount the upper portion of the freeway bar, place the two billet clamps over the two frame tubes with the threaded holes facing outward. Align the clamps so that you can insert the supplied M8 x 16mm bolts through the upper freeway bar bracket and into the billet clamps. **Refer to diagram below. DO NOT FULLY TIGHTEN BOLTS.**
4. Torque the (4) M10 bolts on the lower freeway bar / floorboard mounts to their appropriate factory torque values. Then fully tighten the upper M8 bolts making sure the clamps are seated tight against the frame tubes and do not rotate.

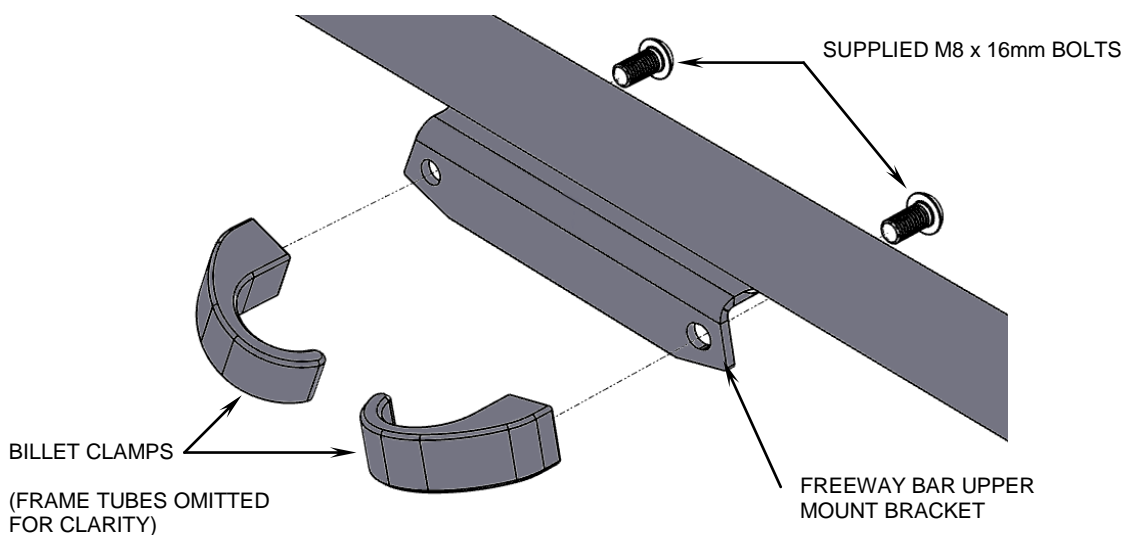

*** Cobra® recommends you always wear a helmet while riding. Please never operate your motorcycle while under the influence of alcohol and/or drugs. Enjoy the new look of your motorcycle and please ride safely.**